



M 1

PRO MIXING CONSOLE

TABLE OF CONTENTS

General Description	20
Input MIC	21
Stereo Input	21
Master A	23
Master B	25
Front Panel	27
Rear Panel	28
Specifications	29
Blockdiagram	33
Dimensions	36
Warranty	37
	44

IMPORTANT SAFETY INSTRUCTIONS

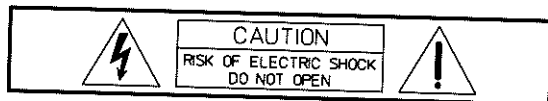

WARNING: TO REDUCE THE RISK OF FIRE OR ELECTRIC SHOCK, DO NOT EXPOSE THIS APPLIANCE TO RAIN OR MOISTURE.
AVIS: RISQUE DE CHOC ELECTRIQUE. NE PAS OUVRIR.



The lightning flash with arrowhead symbol, within an equilateral triangle is intended to alert the user to the presence of uninsulated "dangerous voltage" within the product's enclosure that may be of sufficient magnitude to



The exclamation point within an equilateral triangle is intended to alert the user to the presence of important operating and maintenance (servicing) instructions in the literature accompanying the appliance.

ENGLISH

1. Read these instructions.
2. Keep these instructions.
3. Heed all warnings.
4. Follow all instructions.
5. Do not use this apparatus near water.
6. Clean only with a damp cloth.
7. Do not block any of the ventilation openings. Install in accordance with the manufacturer's instructions.
8. Do not install near any heat sources such as radiators, heat registers, stoves, or other apparatus that produce heat.
9. Only use attachments/accessories specified by the manufacturer.
10. Refer all servicing to qualified service personnel. Servicing is required when the apparatus has been damaged in any way, such as power-supply cord or plug is damaged, liquid has been spilled or objects have fallen into the apparatus, the apparatus has been exposed to rain or moisture, does not operate normally, or has been dropped.

For US and CANADA only:

Do not defeat the safety purpose of the grounding-type plug. A grounding type plug has two blades and a third grounding prong. The wide blade or the third prong are provided for your safety. When the provided plug does not fit into your outlet, consult an electrician for replacement of the obsolete outlet.

IMPORTANT SERVICE INSTRUCTIONS

CAUTION: These servicing instructions are for use by qualified personnel only. To reduce the risk of electric shock, do not perform any servicing other than that contained in the Operating Instructions unless you are qualified to do so. Refer all servicing to qualified service personnel.

1. Security regulations as stated in the EN 60065 (VDE 0860 / IEC 65) and the CSA E65 - 94 have to be obeyed when servicing the appliance.
2. Use of a mains separator transformer is mandatory during maintenance while the appliance is opened, needs to be operated and is connected to the mains
3. Switch off the power before retrofitting any extensions, changing the mains voltage or the output voltage.
4. The minimum distance between parts carrying mains voltage and any accessible metal piece (metal enclosure), respectively between the mains poles has to be **3 mm** and needs to be minded at all times.
The minimum distance between parts carrying mains voltage and any switches or breakers that are not connected to the mains (secondary parts) has to be **6 mm** and needs to be minded at all times.
5. Replacing special components that are marked in the circuit diagram using the security symbol (Note) is only permissible when using original parts.
6. Altering the circuitry without prior consent or advice is not legitimate.
7. Any work security regulations that are applicable at the location where the appliance is being serviced have to be strictly obeyed. This applies also to any regulations about the work place itself.
8. All instructions concerning the handling of **MOS** - circuits have to be observed.

Note:



SAFETY COMPONENT (HAS TO BE REPLACED WITH ORIGINAL PART ONLY)

GENERAL DESCRIPTION

M 1 Pro Mixing Console

- 19" stereo mixing desk with 13 inputs (3 x Mic/Line, 3 x Phono, 7 x Line)
- Digital inputs (optional retrofit) (optical and coaxial)
- Phantom power supply individually switchable
- Mic-Inputs (XLR) electronically balanced (transformer as option)
- Gain control per channel (calibrated in dB)
- Input signal indicator per channel
- Peak LED per channel
- Talk Over function for Mic channels (1, 2 or 3 channels selectable)
- Pan pot for Mic channels
- 3-band equaliser per channel (calibrated in dB)
- EQ Bypass function per music channel
- Transition with routing function per channel (60 mm Panasonic fader)
- PFL and Channel On for all MIC channels
- PFL for all music channels
- Fader start (as option, retrofittable)
- 100 mm Panasonic faders (Alps Studio or Penny & Giles optional)
- 60 mm Panasonic faders for Master A and Master B
- Master A with additional Mono Output or Sub Output (100 Hz/12 dB)
- Master A and Master B output in stereo with electronically balanced XLR outputs (transformer as option, retrofittable) (calibrated in dB)
- Aux-Output in Mono, with control and electronically balanced stereo output (1/4" jack, tip-ring-sleeve)
- Light-Output in Mono, with control and isolated mono output (1/4" jack, tip-sleeve)
- Output level limiter for Master A, Master B and Aux Output
- Effect inserts in stereo for microphone or music channels
- Pre-Listen via Phones Mix function with PFL PRE MASTER control
- 3 Output level meters for Master A and Master B/Phones Mix (calibrated in dB)
- Calibration of level meters possible on the front panel
- Parallel jacks (Cinch) on the front panel for Line In and Tape record
- Recording signal with or without microphone channels
- Powerful headphones output

The mixing desk is the heart of any audio system. It serves to define such a system more than any other component and reflects the expectations regarding sound quality.

The new M1 mixing desk from DYNACORD, developed for demanding, professional users, provides maximum reliability and a whole range of features which meet the constantly increasing requirements expected of modern audio systems in every respect.

No matter whether it is used for rough disco routine, dancing schools or for broadcasting, a mixing desk must be in a position to face and overcome such challenges. The M1 does just that!

A perfect combination of superior components coupled with state-of-the-art design makes the M1 a professional tool for special mixing desk applications and requirements.

The M1 - uncompromising in its versatility!

INPUT MIC

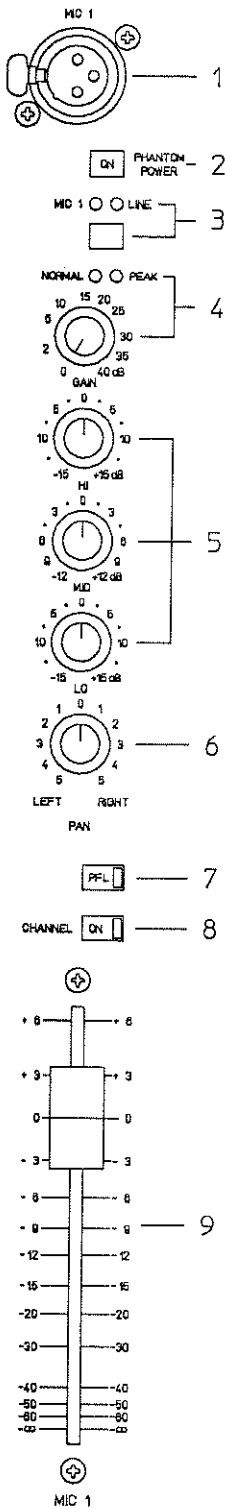

1 MIC

Electronically balanced XLR inputs 1-3 to connect low-Z microphones. Phantom-powered microphones (condensator microphones) can also be connected at these sockets.

XLR Wiring according to IEC 268

This input can be transformer balanced via the optional retrofitting kit NRS 90162.

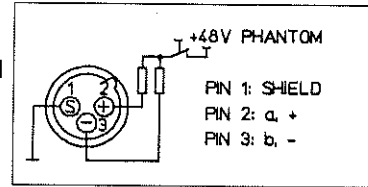

2 PHANTOM POWER

Switch for the 48V phantom power supply of the MIC sockets 1-3.

If phantom-powered microphones (e.g. condensator microphones) are used, they can be powered from the M1 power supply. Separate microphone batteries are therefore unnecessary.

Please only put phantom power supply into operation when the M1 is switched off.

When the phantom power supply is switched on, no unbalanced signal sources must be connected to the MIC-XLR connectors (keyboards, mixing desks). The phantom voltage could damage or destroy the units.

To prevent the unit from being switched on unintentionally, this switch only protrudes minimally from the front panel. Use a slim, blunt object to activate this switch.

3 MIC-LINE switch and indicator

Key to switch over the input sensitivity on the XLR socket.

The sensitivity selected is indicated by an LED lighting up.

MIC - connection of low-Z microphones.

LINE - connection of audio sources such as transmitter micro's, CD player, cassette decks etc.

4 GAIN + NORMAL/PEAK LED

Control to adjust the input sensitivity between -58 dBu (2.5 mV) and -10 dBu (250 mV). (LINE: 25 mV ... 2.5 V).

The control should be set in such a way that the PEAK LED only lights up briefly at peak volumes. This guarantees optimal signal/noise ratio. If the PEAK LED lights up, this indicates that 9 dB headroom is still available before the input signal is distorted audibly. Please note that sound corrections made with the EQ controls also influence the channel signal level. After EQ setting has taken place, please check that the GAIN control has been set correctly.

The GAIN control setting also influences the threshold of the "Talkover" circuit, should this channel have been programmed as a "Talkover" control channel.

All 3 MIC channels can be reprogrammed internally via jumpers.

From the factory, MIC 1 controls "Talkover".

5 EQUALISER

The channel EQ allows an extensive and effective sound control of the the input signal within various frequency ranges. By turning the EQ controls to the right, the corresponding frequency range is boosted. Turning it to the left cuts the corresponding frequency range. When setting the EQ controls, always begin from a neutral starting position - i.e. all controls are in a central detent position (12 o'clock). Try to avoid turning the EQ controls to extreme settings. Normally speaking, slight alterations are sufficient and achieve the best results. Natural- sounding sound reproduction is the best orientation. Rely on your musically trained ear when assessing sound quality. Acoustic feedback can be avoided by particularly sensitive operation of the MID control. Avoid extreme boosting, especially in these frequency ranges. More or less slight reductions minimize the risk of feedback of the signal sources being amplified.

Control	Control range	Frequency	Type
HI	± 15 dB	15 kHz	Shelving
MID	± 12 dB	1,6 kHz	Peak / Dip
LO	± 15 dB	40 Hz	Shelving

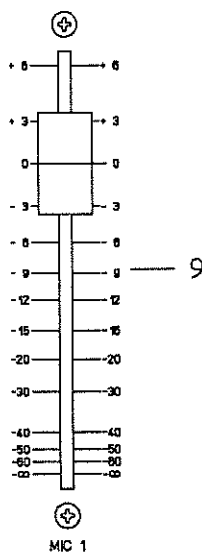
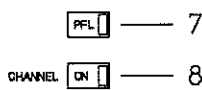
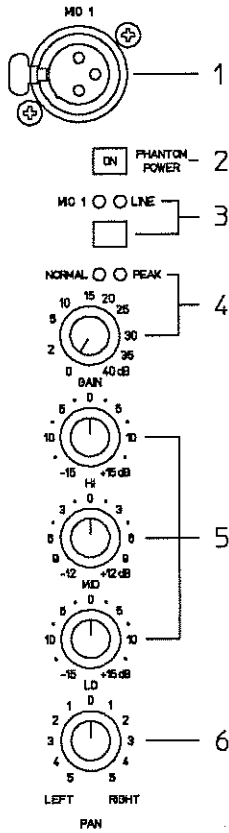
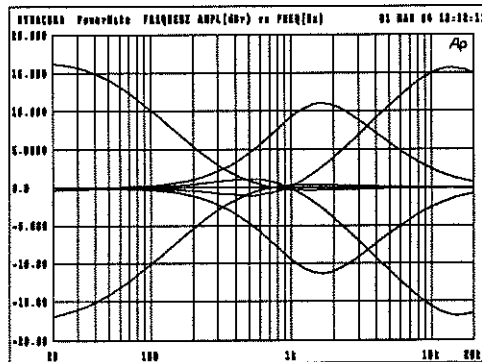

6 PAN

This determines the actual location of the input signal in the stereo image. In a central setting, the signal is divided up equally between the two Masters on the left and on the right.

7 PFL

This switch serves to monitor the signal pre-fader (i.e. also possible with the fader in a closed position). The LED indicates whether the switch has been pressed. If several switches are pressed at the same time, the monitored signal consists of a mixed signal combining all the active signal sources, switched to PFL.

8 CHANNEL ON

The ON switch activates the channel in the signal path, a fact which is indicated by an LED in the switch itself. It is advisable to switch off all the channels not used so as to avoid unnecessary noise in the various ranges of the mix-down.

9 CHANNEL FADER

This serves to adjust the volume of the MIC channel. If the MIC channel has been programmed as a DJ channel (internal jumpers), this fader controls the signal fed to the power amplifiers directly, i.e. absolutely independently of the volume setting of the Master Faders.

The MIC channels can be programmed as music (program) channels via jumpers. Then the fader controls the music master bus directly.

Thus an additional stereo program input can be programmed with MIC 2/3 (PAN pot MIC 2 fully counterclockwise, PAN pot MIC 3 fully clockwise).

From the factory, MIC 1-3 are MIC channels.

This channel fader can be substituted with an ALPS studio fader or a Penny & Giles fader. Please ask your authorized dealer for assistance.

Stereo Program Input Channels

CD 1/2, PHONO 1-3, LINE 1-3, TAPE 1/2

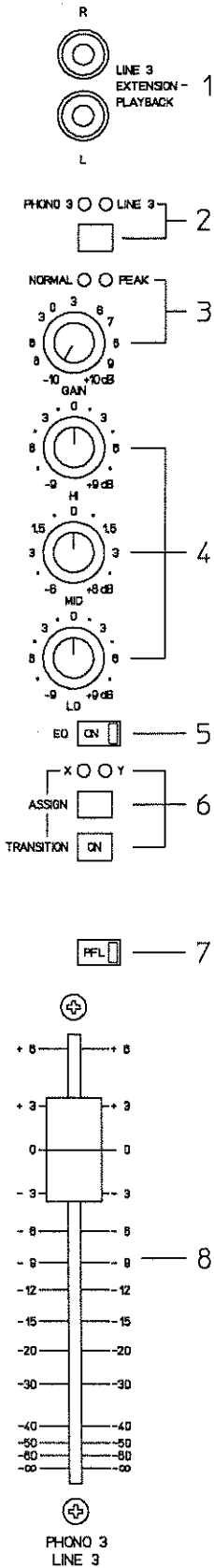

1 LINE 3 EXTENSION PLAYBACK

Cinch sockets parallel to the LINE 3 input sockets at the rear.

2 PHONO 3 - LINE 3 Switch and display

Switch to select 2 stereo input sources.

The input source selected is indicated by an LED lighting up.

PHONO 3 - Connection of turntable magnetic cartridge (every phono input can be reprogrammed internally to LINE sensitivity by jumpers).

LINE 3 - Connection of stereo sound sources such as CD player, DAT, DCC, cassette decks etc.

3 GAIN + NORMAL / PEAK - LED

Rotary control to adjust input sensitivity between -30 dBu (25 mV) and -10 dBu (250 mV). The rotary control should be set in such a way that the PEAK LED only lights up briefly at peak volumes. This guarantees optimal signal/noise ratio. If the PEAK LED lights up, this indicates that 10 dB headroom is still available before the input signal is distorted audibly. Please note that sound corrections with the EQ controls also influence the channel signal level. After EQ setting has taken place, please check that the GAIN control has been set correctly. The NORMAL LED serves as an input signal indicator. It lights up as soon as a signal source is activated. This allows for extremely prompt visual acquiring of all active signal sources.

4 EQUALIZER

The channel EQ allows an extensive and effective sound control of the the input signal within various frequency ranges. By turning the EQ controls to the right, the corresponding frequency range is boosted. Turning it to the left cuts the corresponding frequency range. When setting the EQ controls, always begin from a neutral starting position - i.e. all control markings are in a central detent position (12 o'clock). Try to avoid turning the EQ controls to extreme settings. Normally speaking, slight alterations are sufficient and achieve the best results. Natural- sounding sound reproduction is the best orientation. Rely on your musically trained ear when assessing sound quality.

Control	Control range	Frequency	Type
HI	± 9 dB	10 kHz	Shelving
MID	± 6 dB	1,5 kHz	Peak / Dip
LO	± 9 dB	70 Hz	Shelving

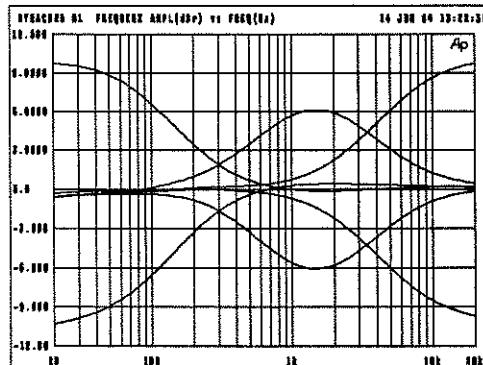

STEREO INPUT

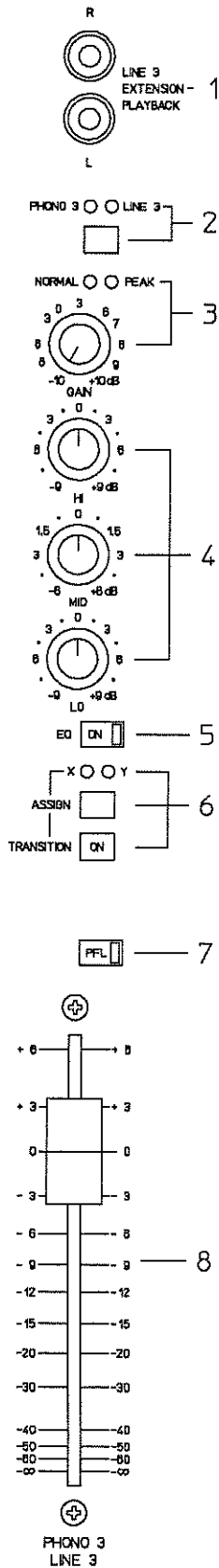

5 EQ ON

This switch loops the equaliser into the signal path. When switched off, the equaliser is bypassed entirely, i.e. the appropriate input channel is linear. It is not possible to influence the sound of the input signal.

6 TRANSITION / ASSIGN

Assignment of channels to the transition control.

The TRANSITION ON switch is used to decide whether you wish to feed out this music channel via the transition control to the Master channel A. If this switch is not pressed, the channel fader (9) feeds the master channel A directly. The transition control then has no function for this particular channel; neither of the two LED's X-Y light up.

Once TRANSITION ON switch has been pressed, one of the two LED's X or Y lights up, depending on the position of the switch ASSIGN. The channel signal is only fed out to the Master channel A if the transition control is in the position X or Y as selected:

LED X (yellow) lights up: the transition control must be placed in position X so the signal is fed out.

LED Y (green) lights up: the transition control must be placed in position Y so the signal is fed out.

In disco applications the transition control serves to achieve a smooth transition between various pieces of music.

TRANSITION/ASSIGN allows the user either to fix all program signal sources as regards Transition/Master A function, or to achieve an absolutely flexible mix of all program signal sources in random order.

7 PFL

This switch serves to listen into the channel in front of the channel fader (i.e. also possible with the control in a closed position). The LED indicates whether the switch has been pressed. If several switches are pressed at the same time, the monitored signal consists of a mixed signal combining all the active prelistened signal sources.

8 STEREO CHANNEL FADER

This fader serves to set the volume of the program channel.

This channel fader can be substituted with an ALPS studio fader or a Penny and Giles fader. A fader start is possible for certain channels. Please ask your authorized dealer for assistance.

1 MASTER A OUTPUT LEVEL

Level meter for the right and left MASTER A output level. The characteristics of the level meter can be altered internally via jumpers.

The following characteristics are available:

- PEAK**/ display of peak levels
 - AVERAGE**/ display of average levels
- Factory setting: **AVERAGE**

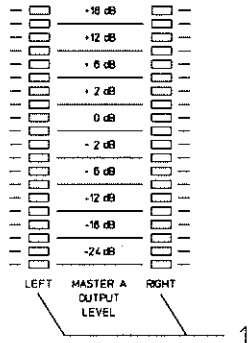

1

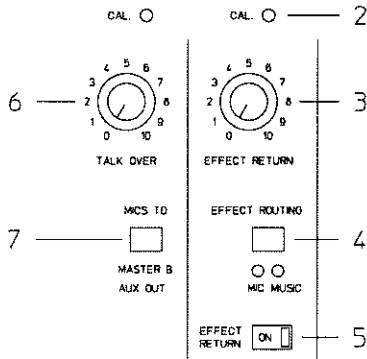

2

3

4

5

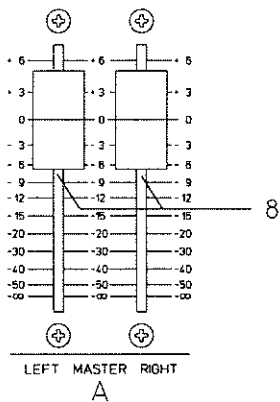

8

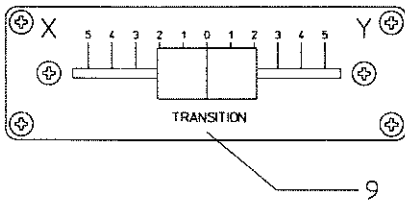

9

2 CAL

These controls located under the front panel can be used to calibrate the level meters to any reference value as required.

Factory setting: 0 dB = 0 dBu (= 775 mV)

3 EFFECT RETURN

This stereo rotary control determines the mix ratio between the original signal and the effect signal (effect volume) when an effect device is connected to the mixing desk.

4 EFFECT ROUTING

This switch is used to determine which signal is applied to the effect unit connected. Either the program music signal (position MUSIC/MUSIC LED lights up) or the microphone signal (position MIC/MIC-LED lights up) mixed with the effect signal.

5 EFFECT RETURN

When the button EFFECT RETURN/ON is lit up, this switches the effect signal set with (3) on or off.

NOTE:

If you decide to use the effect device you have connected in order to influence the program music signal, (Effect Routing position: Music), please switch the effect path off immediately after use (Effect Return switch into position OFF). This is to ensure that subsequent pieces of music are not mixed with an inappropriate effect signal. This permanent, uncontrolled influence of music signals causes a general sound deterioration.

6 TALK OVER

This control is used to set the attenuation of the music signal whilst the DJ is speaking into the microphone. In position 0 the music signal is not attenuated. In position 10 the attenuation amounts to approximately 20 dB.

All 3 MIC channels are prepared for use in conjunction with TALK OVER. The MIC channel in question can be programmed internally via a jumper to determine which MIC channel or channels should trigger the attenuation.

Factory setting: only MIC 1.

Please contact your authorized dealer for assistance.

NOTE!

To avoid attenuation due to feedback, the threshold is set relatively insensitive, i.e. the MIC channel must be well modulated (until the PEAK LED lights up occasionally) to trigger the attenuation function.

7 MICS TO MASTER B/AUX OUT

If this switch has not been pressed, the DJ signal (all MIC signals) is only fed out to Master A. If signals are fed to reinforcement systems of adjacent rooms via the outputs master B or AUX OUT, it is possible to select whether the DJ's announcements should also be audible there or not. If the AUX OUT signal is used for monitoring, the MIC signal can be muted in the AUX channel (risk of feedback!). To do so necessitates moving a jumper internally.

Please approach your authorized dealer for assistance.

8 MASTER A FADER

This fader determines the output level at the output jacks MASTER A OUT and MONO OUT (SUB OUT).

These faders can be substituted for an ALPS Studio fader or a Penny & Giles fader if required.

Please contact your authorized dealer for assistance.

9 TRANSITION FADER

Fader to cross-fade sound sources. Use the FUNCTION/ASSIGN function to select which sound sources are to be cross-faded in the appropriate channel.

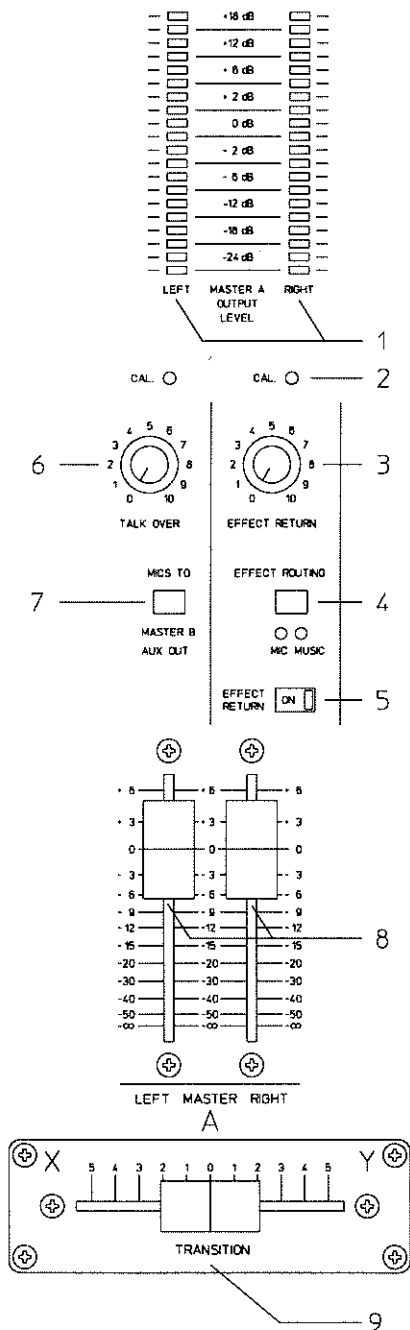

MASTER B

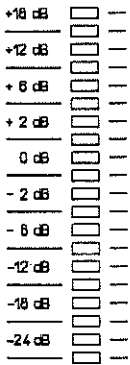

PHONES MIX
MASTER B
LEVEL

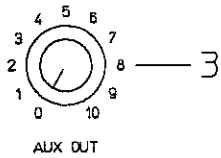
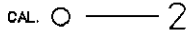

METER SELECT

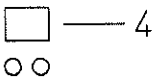

PHONES MIX MASTER B

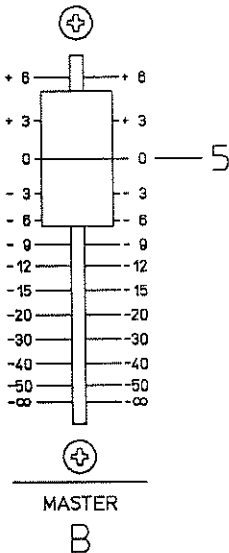

1 MASTER B/HEADPHONES OUTPUT LEVEL

Level Meter for the MASTER B or PHONES MIX output level.

The characteristics of the level meters can be altered by jumpers.

The following characteristics are available:

PEAK - peak level display

AVERAGE - average level display

Factory setting: **AVERAGE**

2 CAL

This trim potentiometer located under the front panel is used to calibrate the level meter to any reference level as required.

Factory setting: 0dB = 0 dBu (775mV).

3 AUX OUT (Mono)

This control sets the signal strength at the AUX OUT stereo jack; (for adjacent rooms, monitoring etc.)

4 METER SELECT

Use this switch to select which signal the above level meter (1) should show:

Output signal Master B or the headphones signal, PHONES MIX

5 MASTER B FADER

This stereo fader determines the output level on the output jacks Master B OUT.

FRONT PANEL

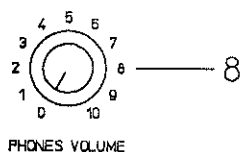
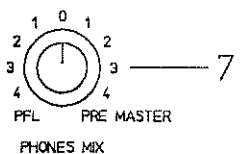
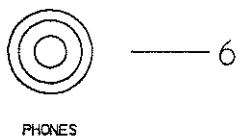
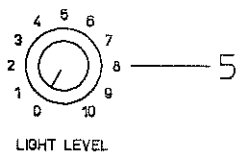
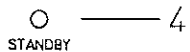
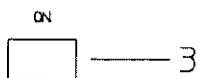
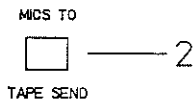
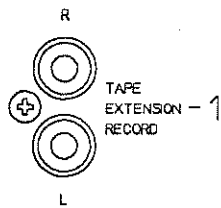

1 TAPE EXTENSION RECORD

Cinch sockets for Tape Record (parallel to the record jacks at the rear). These output jacks can be used for tape or cassette recordings. The signal is independent of the settings of the master faders.

2 MICS TO TAPE SEND

This switch is to decide whether to include the microphone signal in a recording of the music signal or not.

3 ON

ON/OFF switch (function switch)

The LED's on the various switches on the front panel indicate whether the unit is switched on or off.

4 STANDBY

This LED is lit up as soon as the mixing desk is connected with the mains, regardless of the position of the ON switch (3).

The mixing desk is ready for operation as soon as the switch ON (3) has been pressed.

5 LIGHT LEVEL

This rotary control serves to drive the light effect units which are connected.

6 PHONES

The stereo headphones are connected here. Recommended headphones impedance: 16-200 ohm.

Please refrain from using a 1/4" mono plug because this would short circuit the right-channel output amplifier.

Note!

The special circuit technology of the headphones amplifier means that the ground of the headphones jack must not be connected with the mixing desk ground.

7 PHONES MIX

This rotary control can be used to obtain a mix consisting of the PFL signal and the PRE-MASTER signal on the headphones. This is an easy way to adjust the "beat" of the pre-listened music to the "beat" of the current music.

All pre-listened music signals are applied always to both headphones channels which means that you can work with one or two headphone earpieces according to personal preference.

In large discotheques, synchronization problems can crop up due to runtime delays resulting from the main system, i.e. you do not hear the current music signal at the same time as the pre-listen signal. With the PHONES MIX function you can pre-listen only the PFL signal or only the PRE MASTER signal (= current music signal), depending on the position of the PHONES MIX control, or any mixture of PFL/PRE MASTER, i.e. the PHONES MIX function allows you to make quick, perfect and synchronous transitions.

8 PHONES VOLUME

This rotary control serves to set the headphones volume.

REAR SIDE/INPUTS

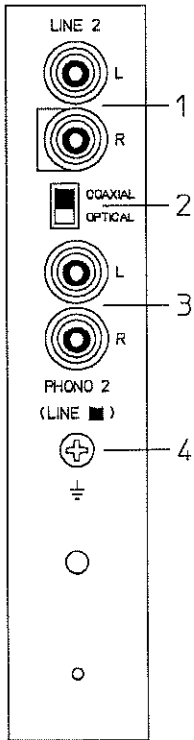

1 CD/LINE INPUT

Cinch sockets L + R for high-level sound sources such as CD player, DAT recorder, cassette decks, tape machines, tuners etc.

This input is selected via the switch (2) on the front panel.

If a digital input was retrofitted, the socket designated "L" is the coaxial digital input, and the gap of the socket "R" is the connector for the optical fibre digital input.

2 DIGITAL INPUT SELECT

Only if a digital input (NRS 90 182) has been retrofitted.

A slide switch is visible in this particular case. It can be used to decide the digital mode of transmission from the source to the mixing desk.

In the position "COAXIAL", the coaxial input (socket "L") is active. In position "OPTICAL" the optical fibre input on the socket "R" is active, (see 1).

3 PHONO (LINE)/TAPE INPUT

Each of these inputs (with the exception of the digital input) can be reprogrammed from PHONO to LINE sensitivity (and vice versa) with 2 jumpers.

Please approach your authorized dealer for assistance.

Factory setting: as labelled on front and rear panel.

If PHONO inputs are later adjusted to line sensitivity, this can be designated on the input jacks in question.

This input is selected via the switch 2 on the front panel.

4 CLAMPING SCREW

Earthing screw for turntables' earth connection.

5 DIGITAL INPUT CONNECTION

This explanation is located at the rear of the unit and indicates the connection of a retrofitted digital input.

The M1 input channels CD 1, CD 2, LINE 1 and LINE 2 are prepared for that retrofitting.

A maximum of 3 digital input channels can be retrofitted.

The second (analog) input of the digital retrofitting kit has LINE sensitivity and can be used in addition.

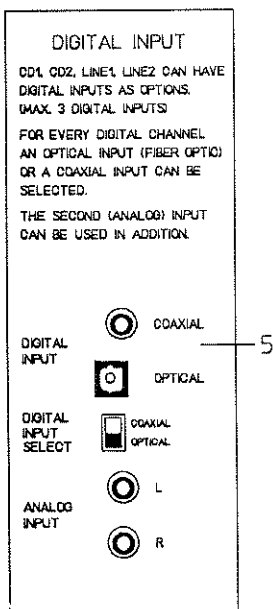

ENGLISH

REAR SIDE/OUTPUTS

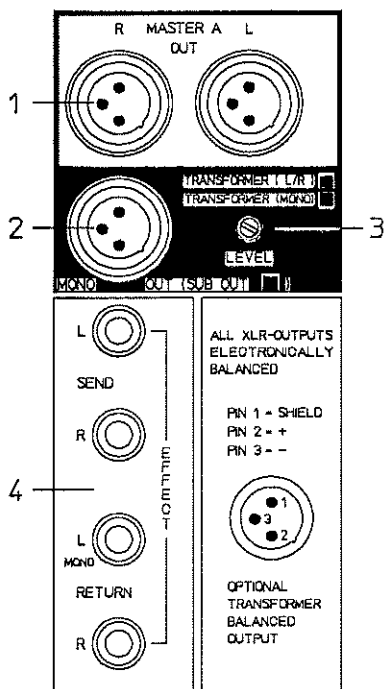

1 MASTER A OUTPUT (MAIN STEREO OUTPUT)

These XLR outputs are electronically balanced and can be transformer balanced with the aid of the retrofitting kit NRS 90 183 which contains 1 x transformer. When the unit is switched on, the outputs are activated with a delay and switched off first when the unit is switched off, in order to keep obtrusive switching on/off noises away from the sound reinforcing system.

If an output transformer is retrofitted, the connectors can be designated accordingly.

2 MONO OUTPUT or SUB OUTPUT MASTER A

This XLR output is also electronically balanced, can be retrofitted with a transformer (retrofitting kit NRS 90 183) and is equipped with an output relay.

The signal on this socket is the mono balanced signal of the main outputs Master A, which means that this output does not possess its own fader. The level is always the same as the one at the main output Master A.

By relocating 2 jumpers inside the unit, this MONO-OUT can be altered to a SUB-OUTput, i.e. the looped-in low-pass filter only transfers frequencies below 100 Hz to the SUB-OUT output socket.

Simple full-range sound systems can be realized in this way. They can be supplemented without an additional active crossovers with one or more subwoofers.

If an output transformer is retrofitted or the system is altered to SUB-OUT, this can be designated on the socket in question.

Please approach your authorized dealer for assistance.

3 LEVEL TRIM CONTROL FOR MASTER A R/L AND MONO OUT (SUB OUT)

Factory setting: extreme right

This trim control can be used to adjust the output voltage of these outputs to the input sensitivities of the power amplifiers connected, without having any influence on the output level meters on the mixer panel.

Full modulation of the power amplifiers can, for example, be adjusted to the 0 dB mark of the mixer level meter.

You can also assign a certain value of the level meter to a predetermined volume (volume limitation).

4 EFFECT INSERT JACKS

The EFFECT SEND jacks are connected to the input jacks of the effect unit.

The EFFECT RETURN jacks are connected to the output jacks of the effect unit.

In the case of a MONO effect unit, please use the upper jack (L) in each case.

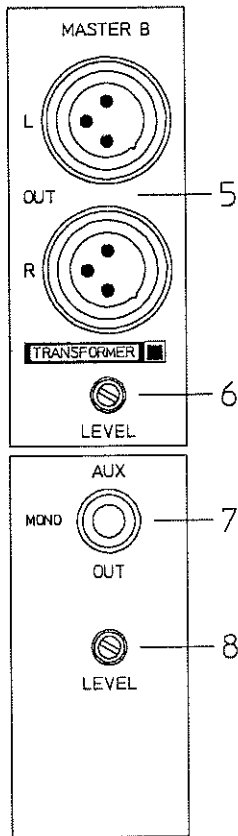

5 MASTER B OUTPUT (STEREO)

These XLR outputs are electronically balanced and can be transformer balanced with the aid of the retrofitting kit NRS 90 183 which contains 1 x transformer. When the unit is switched on, the outputs are activated with a delay and switched off first when the unit is switched off, in order to keep obtrusive switching on/off noises away from the sound reinforcing system.

If a output transformer is retrofitted, the connectors can be designated accordingly. Please contact your authorized dealer for assistance.

6 LEVEL TRIM CONTROL FOR MASTER B R/L

Factory setting: extreme right

This trim control can be used to adjust the output voltage of these outputs to the input sensitivities of the power amplifiers connected, without having any influence on the output level meters on the mixer panel.

Full modulation of the power amplifiers can, for example, be adjusted to the 0 dB mark of the mixer level meter.

You can also assign a certain value of the level meter to a predetermined volume (volume limitation).

7 AUX OUTPUT (MONO)

This mono output is electronically balanced, i.e. the 1/4" output jack is stereo (tip-ring-sleeve). If a mono jack is connected, this output is then unbalanced. It can be used to provide sound signals for amplifiers in adjacent rooms or for monitoring purposes.

When the unit is switched on, the outputs are activated with a delay and switched off first when the unit is switched off, in order to keep obtrusive switching on/off noises away from the sound reinforcing system.

8 LEVEL TRIM CONTROL FOR AUX OUTPUT

Factory setting: extreme right

This trim control can be used to adjust the output voltage of this output to the input sensitivity of the power amplifier connected.

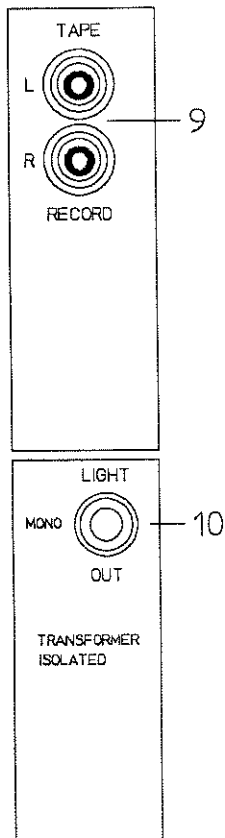

9 TAPE RECORD

Cinch sockets for TAPE RECORD (parallel to the TAPE RECORD sockets on the front panel).

Output sockets for tape or cassette recordings. This signal is independent of the Master fader settings.

10 LIGHT OUTPUT (MONO)

Transformer balanced mono output jack to control light effects units. This signal is independent of the Master fader settings and those of the Talkover control.

REAR PANEL

PULL POWER PLUG
BEFORE OPENING

230V ~ 50-60Hz

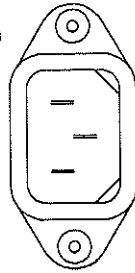

MAINS SOCKET

The enclosed mains cable is plugged into this socket. For reasons of safety, to avoid short circuits and fire risk, only use mains cables supplied by the factory.

A drill hole is located at the rear of the for the enclosed cable clamp.

Please slot the mains cable into this clamp after the mains cable has been plugged into the mixing desk. (see diagram on page 54)

This ensures that the mains plug cannot drop out by accident when the mixing desk is being removed.

MAINS
FUSE
T 1 A



Mains Fuse

If the appropriate fuse is faulty, the mixing desk cannot be switched on. If the fuse is blown out, it may only be replaced by a fuse of the prescribed type.

The green Standby LED on the front of the mixing desk goes off when the mains connection is correct but the fuse is faulty.

CIRCUIT 1 TO
CHASSIS SWITCH



GROUNDING



UNGROUNDING



Groundlift switch

This switch separates the chassis from the circuit ground to prevent hum loops. Hum loops can occur when several units are inter-connected with their ground via the protective earth conductor on the mains outlets, in rack installations via the metallic connection of the chassis, and via the shield of the AF signal lines.

SPECIFICATIONS M1

Measuring conditions

- All faders into position "+6dB", all level controls to position "10"
- Gain variable, Output level trim control fully right
- 775 mV = 0 dBu, f = 1 kHz

General Specifications:

Mains voltage:	230 VAC
Mains frequency:	50 Hz...60 Hz
Rated power consumption:	45 VA
Tolerance of mains voltage:	± 10%
Safety class:	I
Dimensions (WxHxD) in mm:	483 x 399 x 163
Mounting dimensions (WxHxD) in mm:	450 x 385 x 200
Weight:	9 kg

Input Characteristics (at output level +4 dBu):

Input	Rated Input Level	Max. Input Level	Input Impedance
MIC	- 55 dBu ... - 25 dBu	- 30 dBu ... 0 dBu	3.3kOhm
LINE via MIC	- 35 dBu ... - 5 dBu	- 9 dBu ... + 20 dBu	16 kOhm
LINE / TAPE / CD	- 24 dBu ... - 4 dBu	+ 4 dBu... >+22dBu	49 kOhm
PHONO	- 62 dBu ... - 42 dBu	- 34 dBu ... -14dBu	47 kOhm / 100 pF
EXTERNAL INPUT	- 24 dBu ... - 4 dBu	+ 4 dBu ... >+22dBu	49 kOhm
EFFECT RETURN / music	- 8 dBu	+16 dBu	8 kOhm ... 16 kOhm
EFFECT RETURN / mic	+ 8 dBu	+16 dBu	8 kOhm ... 16 kOhm
DIGITAL	- 28 dBFS ... - 8 dBFS	0 dBFS	
LINE/CD via Dig.Input	- 24 dBu ... - 4 dBu	+ 13 dBu	22 kOhm

Output Characteristics (at rated input level)

Output	Rated Output Level	Max. Output Level	Output Impedance
MASTER A L/R	+ 4 dBu	+ 27 dBu	75 Ohm
MONO OUT	+ 4 dBu	+ 27 dBu	75 Ohm
AUX OUT	+ 1 dBu	+ 22 dBu	75 Ohm
MASTER B L/R	+ 4 dBu	+ 27 dBu	75 Ohm
EFFECT SEND	- 11 dBu	+ 12 dBu	75 Ohm
TAPE RECORD	- 8 dBu	+ 10 dBu	75 Ohm
HEADPHONES	+ 17 dBu / 200 Ohm	+ 24 dBu / 200 Ohm + 28 dBu / 600 Ohm	18 Ohm
LIGHT OUT	+ 12 dBu	+ 22 dBu	---

SPECIFICATIONS

Noise voltages

- Measuring bandwidth 22 Hz ... 22 kHz
- Noise voltage measurement according to IEC 268-1, RMS
- Source resistor MIC 150 ohm, LINE 50 ohm

Measurement	Result	Comment
Equivalent Input noise MIC - INPUT (EIN)	- 123 dBu	Gain max.
Equivalent Input noise LINE/CD/TAPE - INPUT (EIN)	- 96 dBu	Gain max.
Equivalent Input noise LINE via MIC - INPUT (EIN)	- 92 dBu	Gain max.
Mixer Bus noise A	- 78 dBu	Master-Fader max.
Mixer Bus noise B	- 82 dBu	Master-Fader max.
Typical Mixer noise A	- 82 dBu	All fader pos. "0"

Equalizer (LO/Hi shelving , MID peaking):

Equalizer	LO	MID	HI
MIC/LINE	+/-15 dB / 40 Hz	+/-12 dB / 1.6 kHz	+/-15 dB / 15 kHz
LINE / CD / TAPE	+/-9 dB / 70 Hz	+/-6 dB / 1.6 kHz	+/-9 dB / 10 kHz

Crosstalk and Attenuation:

Measurement	f= 1kHz	f= 10 kHz
CHANNEL ON switch attenuation	> 90 dB	> 70 dB
MIC - Channel fader attenuation	> 80 dB	> 65 dB
LINE - Channel fader attenuation	> 100 dB	> 85 dB
PHONO/LINE switch attenuation	> 90 dB	> 80 dB
CD/TAPE switch attenuation	> 90 dB	> 70 dB
EFFECT RETURN ON switch attenuation	> 95 dB	> 75 dB
EFFECT RETURN fader attenuation	> 70 dB	> 70 dB
TRANSITION X/Y fader attenuation	> 50 dB	> 50 dB
MASTER A fader attenuation	> 100 dB	> 85 dB
MASTER B fader attenuation	> 110 dB	> 95 dB
CHANNEL to CHANNEL crosstalk	> 80 dB	> 80 dB
L/R crosstalk	> 70 dB	> 45 dB

Nonlinear Distortions

- Channel fader into position "0"
- Master fader into position "+6"
- Gain variable, E(I) = +4 dBu, E(O) = +16 dBu
- Measuring bandwidth: f = 10 Hz ... 80 kHz

Distortion (THD+N):

Input – Output	THD+N at 1 kHz	THD+N at 10 kHz
LINE / TAPE / CD to MASTER A L/R	< 0.003 %	< 0.006 %
LINE / TAPE / CD to MASTER B L/R	< 0.003 %	< 0.006 %
LINE via MIC INPUT to MASTER A L/R	< 0.015 %	< 0.06 %
MIC to MASTER A L/R	< 0.015 %	< 0.04 %

Distortions due to intermodulation:

Measurement	Result	Comment
IM-SMPTE	0.025 %	(60 Hz, 7 kHz)
DIM 100	0.005 %	dynamic

SUB OUT: MONO OUT internal to SUB OUT f (-3dB) = 75 Hz / 2nd order / low-pass filter codeable.

Frequency response - deviation: any input --> any output (20 Hz ... 20 kHz)

0dB/-0.5 dB against nom. frequency 1 kHz.

Common mode rejection ratio (CMRR) MIC Input: CMRR > 60 dB

TALK-OVER attenuation: variable, 0 dB ... 20 dB

Output level meter: 20 segment LED bargraph Peak/Averaged Display with possibility of external adjustment.

Retrofitting kits:

Digital Input: CD 1, CD 2, LINE 1, LINE 2
NRS 90 182 = 1 x PCB
max. 3 pieces retrofittable

Input transformer: MIC Input
NRS 90 162 = 1 x transformer
max. 3 pieces retrofittable

Output transformer: MASTER A OUT, MASTER B OUT, MONO/SUB OUT
NRS 90 183 = 1 x transformer
max. 5 pieces retrofittable

- Alterations without prior notice! -

Blockdiagram

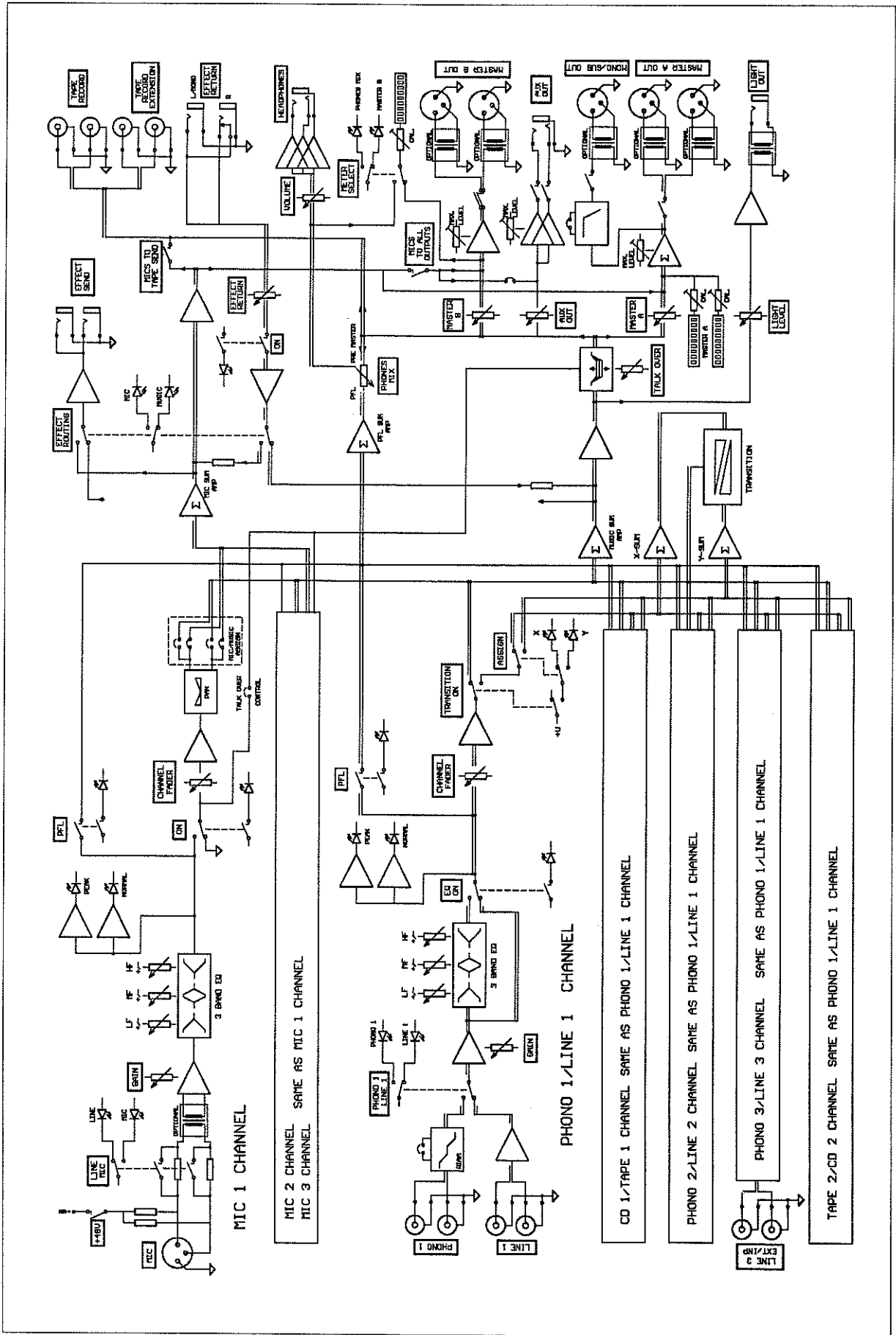

Abmessungen (in mm)
Dimensions (in mm)

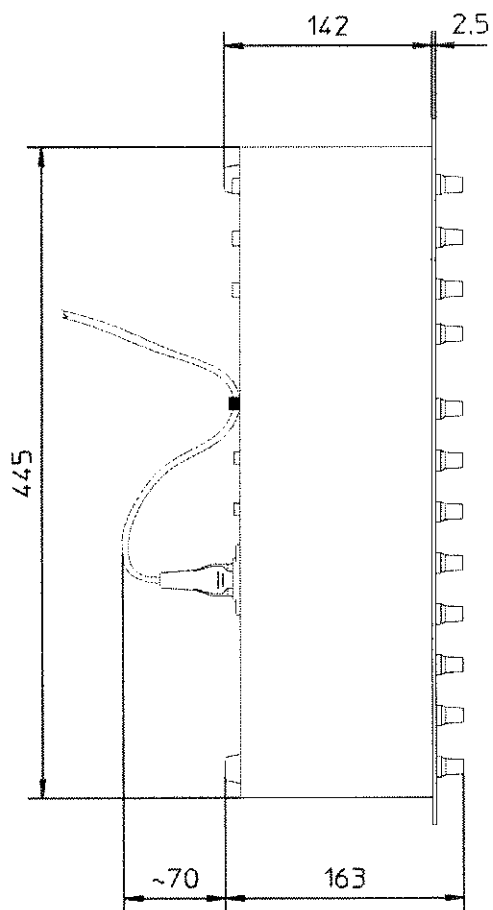
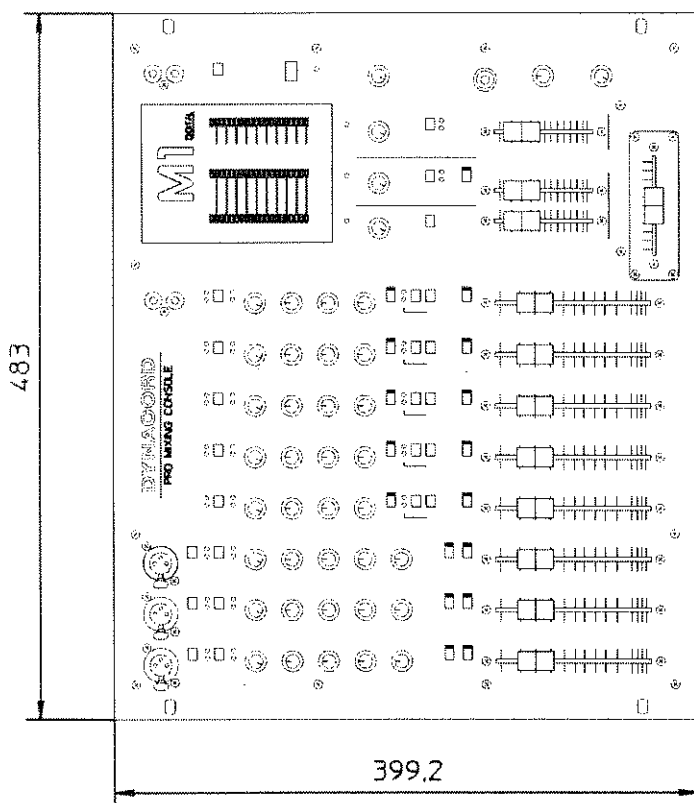
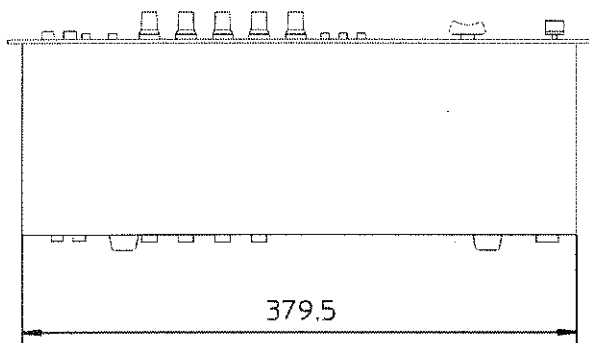

WARTUNG UND SERVICE

DYNACORD Geräte sind Qualitätserzeugnisse. Umfangreiche Wareneingangskontrollen sorgen für eine einwandfreie Qualität der einzelnen Bauteile.

Die Geräte werden, bevor sie das Werk verlassen, einem Dauertest über mehrere Stunden unterzogen. Auf unsere Erzeugnisse gewähren wir im Rahmen unserer allgemeinen Bedingungen eine Garantie von 36 Monaten. Die Garantieleistung erlischt im Falle eines Fremdeingriffs oder bei einem Defekt, der auf Falschanwendungen zurückzuführen ist.

Im Servicefall wenden Sie sich bitte an Ihren Fachhändler oder an die nächste Servicewerkstätte.

SERVICE AND MAINTENANCE

DYNACORD products are highquality products. Extensive and strict inspections of all components ensure perfect and consistent quality of all parts and final product.

Prior to leaving our factory, the units are subjected to an endurance test for several hours. Within the scope of our general conditions of sale we offer a warranty of 36 months on our products. This warranty does not apply to defects or damages caused by unauthorized repair or to damage due to misuse.

If the unit becomes defective, please apply to the nearest authorized service station or to your dealer or importer.

