

IPX20:4 DSP power amplifier 4x5000W, install

IPX Series



- 4 x 5000 W multichannel installation DSP amplifier with digitally controlled PFC supply
- Fully integrated DSP with native 96 kHz and FIR Drive technology
- Dante and OCA integration via OMNEO with fallback options
- Parallel mode with 70/100/140 V and low impedance operation
- High efficiency Eco Rail technology for lower operating costs

Parts included

Quantity	Component
1	IPX series DSP power amplifier
1	8-pin Euroblock-type connector, Output, 6 mm
2	6-pin Euroblock-type connector, Input
1	8-pin Euroblock-type connector, GPIO
4	M6x20 screw for rack mounting
1	Installation manual
1	Mains power connector, 32 A with safety & assembly instruction
1	Safety instruction booklet

Technical specifications

OUTPUT POWER

Low-Z mode: Load Impedance	2 Ω	2.7 Ω	4 Ω	8 Ω
Maximum Output Power¹				
Normal Mode, all channels driven	5200 W	6000 W	5000 W	2500 W
Bridge		n.a.		
Parallel	10000 W	8000 W	5000 W	
Parallel-Bridge		n.a.		
Direct Drive Mode: Nominal Voltage	70 V	100 V	140 V	

Maximum Output Power¹	3550 W	5000 W	5000 W
Number of Amplifier Channels		4	
Maximum Output Voltage, Normal mode, per channel		210 V _{peak}	
Maximum Output Current, Normal mode, per channel		84 A _{peak}	
AMPLIFIER			
Voltage Gain			
Low-Z mode, ref.1 kHz	32.0 dB, adjustable 20.0-44.0 dB		
Direct Drive mode	33.2/36.2/39.2 dB for 70/100/140 V		
Input Sensitivity			
Low-Z mode, Max. Output Voltage	13.7 dBu (3.73 V), adjustable 1.7-25.7 dBu		
Direct Drive mode	6 dBu (1.55 V), fixed		
THD 3 dB below max, AES17, 1 kHz	< 0.05 %		
DIM 100 3.15 kHz, 15 kHz	< 0.15 %		
IMD-SMPTE 60 Hz, 7 kHz	< 0.15 %		
Crosstalk ref. 1 kHz, 12 dB below Max, 8 Ω	< -80 dB		

Frequency Response ref. 1 kHz, analog in to speaker out	20 Hz to 20 kHz (± 1.0 dB)
Damping Factor 20 Hz to 200 Hz, 8 Ω	> 400
Output Stage Topology	Class D, fixed frequency
Signal to Noise Ratio Amplifier	
A-weighted, analog input	115 dB
A-weighted, digital input	118 dB
Output Noise	
A-weighted, analog input	< -70 dBu
A-weighted, digital input	< -73 dBu
CONNECTIVITY	
Analog Audio Input/Thru	
Type	2 x 6-pin Euroblock, male
Maximum Input Level	+21 dBu
Input Impedance, active balanced	20 k Ω
Reference level equal to digital input	+21 dBu for 0 dBFS
Speaker Output	1 x 8-pin Euroblock, 6 mm, female
GENERAL	
Power Consumption	
Rated power consumption (see BTU table)	2250 W
1/8 Maximum Output Power at 4 Ω	2850 W
Idle Mode (no input signal)	110 W
Standby Mode	< 19 W
Dimensions (W x H x D), mm	483 x 88.1 x 514.2
Weight	18.3 kg (40.3 lb)
Shipping Weight	20.5 kg (45.1 lb)
DIGITAL SIGNAL PROCESSING	
Sampling rate	48 kHz/96 kHz, OMNEO/Dante synchronized
Signal delay/latency	0.70 ms/0.53 ms
Analog In to Speaker Out, 48 kHz/96 kHz	
Dante Network Latency	typ. 1.00 ms
Signal Processing	

User EQ	12 filters per channel, selectable as PEQ, Lo-Shelv, Hi-Shelv, Lo-ShelvQ, Hi-ShelvQ, Hi-Pass, Lo-Pass and Notch; 2 filters of them with additional asymmetric filter type
User Delay	0 to 2000 ms per channel (units: μ s, ms, s, cm, m, inches, feet)
Array EQ	5 filters per channel, selectable as PEQ, Lo-Shelv, Hi-Shelv, Lo-ShelvQ, Hi-ShelvQ, Hi-Pass, Lo-Pass, and All-Pass
Array Delay	0 to 500 ms per channel (units: μ s, ms, s, cm, m, inches, feet)
Speaker EQ	10 filters per channel, selectable as PEQ, Lo-Shelv, Hi-Shelv, Hi-Pass, Lo-Pass and All-Pass
Speaker X-Over	Hi-Pass, and Lo-Pass per channel, 6/12/18/24/30/36/42/48 dB Bessel/Butterworth, 12/24/48 dB Linkwitz-Riley; Alignment Delay, 0 to 20 ms per channel
Speaker FIR	Up to 1025 taps, Linear Phase Filter, Linear Phase Brickwall X-Over
Speaker Limiters	Peak Anticipation Limiter and RMS/TEMP Limiter per channel
Other Functions	Source Selection and Mix, Level, Mute, Polarity, Sine and Noise Generator, Pilot Tone Generator and Detection, Level Meters, Impedance Measurement and Load Monitoring
Memory	
DSP Presets	1 Factory + 20 User
Source Supervision and Fallback	Pilot Tone supervision at Analog and OMNEO/Dante inputs, switchover to alternative Source Selection
CONNECTIVITY	
Network	
Type	2 x Neutrik EtherCON/RJ45, redundant PRIMARY/SECONDARY
General	1000base-T/100base-TX, integrated switch
Network Audio Inputs	8 channels, 48/96 kHz, OMNEO/Dante format
Network Audio Outputs (Monitor)	2 channels, 48/96 kHz, OMNEO/Dante format
Mains Input	1 x Neutrik powerCON-HC
GPIO Control Port	
Type	1 x 8-pin Euroblock, male
Ports and Operating Modes	3 x GPIO, switchable Analog In/Digital In/Digital Out Modes
Analog Input Range	0 V to +13 V, 40 k Ω input resistance
Digital Input Limits	ON: < 1.5 V OFF: > 2.0 V, internal Pull Up (10 k Ω)
Digital Outputs	ON: Output switched to GND, max. 200 mA OFF: Open Collector (40 k Ω to GND)
Reference Voltage Output	+10 V, max. 200 mA, supervised, short circuit protected
READY/FAULT contact	Galvanic isolated relay, max. 30 VDC/500 mADC
GENERAL	
User Interface	
Display	Black/white OLED 256 x 64 pixel
Front panel indicators	4 x status LEDs (POWER, STANDBY, FAULT, OMNEO)
Front panel operating elements	3 buttons (UP, ENTER, DOWN)

Rear panel indicators	1 x status LED (STATUS)
Rear panel operating elements	Mains Switch
Power Requirements	100 V to 240 V, 50 Hz to 60 Hz AC
Power Supply Topology	Switching Mode Power Supply with digital controlled Power Factor Correction
Protections	Audio Limiters, High Temperature, DC, HF, Short Circuit, Back-EMF, Peak Current Limiters, Inrush Current Limiters, Turn-on Delay, Mains Circuit Breaker Protection, Mains Over-/Under voltage Protection
Cooling	Front-to-rear, temperature controlled fans, supervised

Ambient Temperature Limits	+5 °C to +40 °C (+40 °F to +105 °F)
IEC Protection Class	Class I (grounded)
Electromagnetical Environment	E1, E2, E3
Color	Black

Amplifier at rated conditions, Low-Z Normal operation mode, all channels driven, 4 Ω loads, Analog input, 32 dB Gain, 48 kHz sample rate, unless otherwise specified.
¹Test signal for max. output power according IHF-A-202 (Dynamic-Headroom, burst 1 kHz/20 ms on/480 ms off/low level -20 dB).

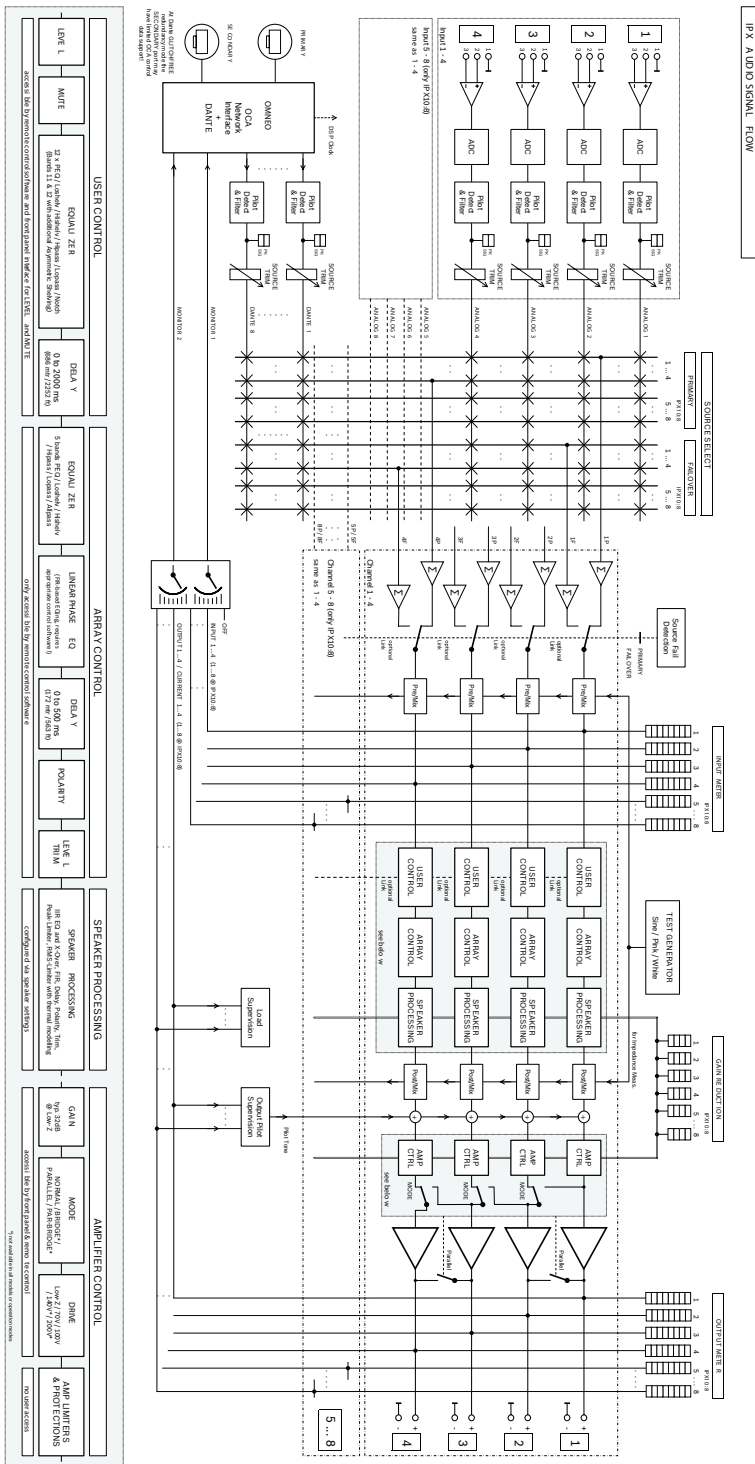

Fig. 1: Block diagram: IPX

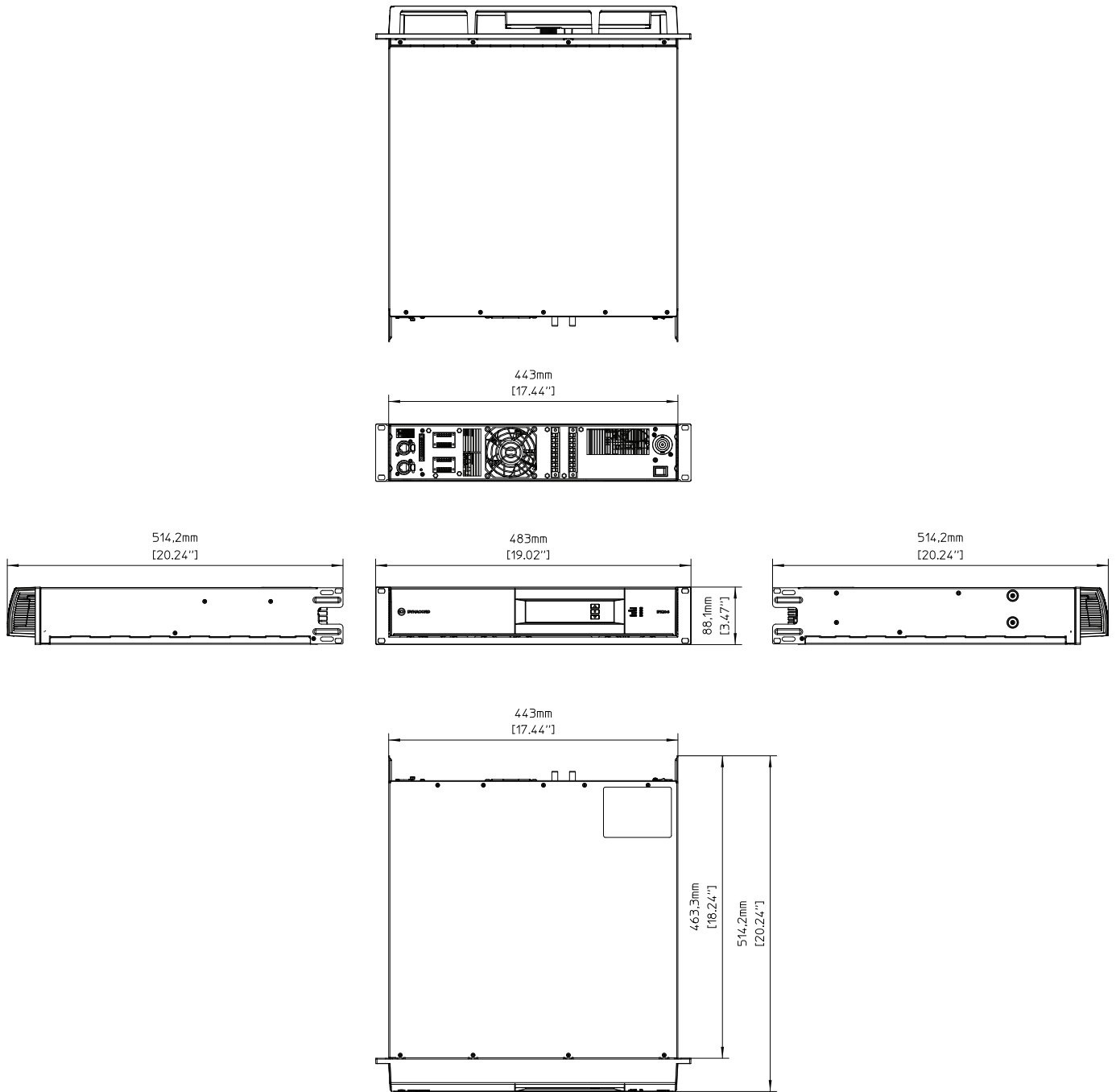

Fig. 2: Dimensions: IPX

Ordering information

IPX20:4 DSP power amplifier 4x5000W, install

DSP power amplifier 4x5000W @ 4 ohms, 8 OMNEO/Dante inputs, 4 analog inputs, hi-z direct drive, GPIOs, euro-block connectors, 100 - 240 V, black

Order number **IPX20:4** | **F.01U.329.718**

Accessories

PCO32A30-US Power cord, powerCon32/NEMA L5-30

Power cord, powerCON32 to NEMA L5-30 mains connector, 2m, black

Order number **PCO32A30-US** | **F.01U.349.975**

PCO32A16-EU Power cord, powerCon32/CEE7/7

Power cord, powerCON32 to CEE7/7 (Schuko, 16A) mains connector, 2m, black

Order number **PCO32A16-EU** | **F.01U.349.976**

PCO32A16-UK Power cord, powerCon32/BS1363

Power cord, powerCON32 to BS1363 (UK-plug) mains connector, 2m, black

Order number **PCO32A16-UK** | **F.01U.349.977**

DC-RMK15 Rear rackmount kit for amplifiers

Rack Mount Kit for amplifiers, Length 15,5"; 1L/1R

Order number **DC-RMK15** | **F.01U.135.402**



<https://www.dynacord.com>