



Application Note

PROMATRIX 6000

Loudspeaker Line Supervision – v1.0

Related Products:

PROMATRIX 6000 System

Severity:

- Immediate action required
- Action strongly recommended
- Informative

PROMATRIX 6000 Loudspeaker Line Supervision

This application note describes what must be observed when using loudspeaker line supervision and provides assistance in operation and troubleshooting.

Table of Contents

- 1. Introduction**
- 2. Impedance Measurement**
 - 2.1. Definition/Description
 - 2.2. How to setup IMP Measurement
 - 2.3. IMP Troubleshooting
 - 2.4. Tips and Tricks
- 3. EOL Supervision**
 - 3.1. Definition/Description
 - 3.2. How to setup EOL Supervision
 - 3.3. EOL Troubleshooting
 - 3.4. Tips and Tricks
- 4. PEOL Supervision**
 - 4.1. Definition/Description
 - 4.2. How to setup PEOL Supervision
 - 4.3. PEOL Troubleshooting
 - 4.4. Tips and Tricks
- 5. Combination of Loudspeaker Line Supervision Methods**
- 6. Pilot Tone**
- 7. Ground Fault Supervision**
- 8. Loudspeaker Line Supervision and In-Line Volume Control**
- 9. Loudspeaker Cables**
- 10. Loudspeaker Line Supervision Comparison Table**

1. Introduction

This Application Note covers the different types loudspeaker line supervision. It explains what to consider when using loudspeaker line supervision and provides help with operation and troubleshooting.

The PROMATRIX 6000 system offers three different options for loudspeaker line supervision. They differ in performance, cost, and suitability for various applications and situations.

IMP

Loudspeaker line impedance measurement

EOL

Pilot tone signal supervision, using addressable EOL modules EOL 8001

PEOL

Pilot tone signal supervision, using non addressable EOL modules PLN-1EOL

The system can detect open circuit and short circuit. In case of an open circuit only a fault message will be generated. In case of a short circuit a fault message will be generated and that particular loudspeaker line will be automatically deactivated to prevent interference with other loudspeaker lines.

NONE

Loudspeaker line can also be left unsupervised. In that case, system will only notify ground fault.

Notice!

For EN54 certified systems, you must use permanent impedance measurement or End of Line monitoring using EOL 8001 or PLN-1EOL boards. See also the PROMATRIX 6000 Declaration of Performance (DoP). EOL or PEOL monitoring is recommended for a voice evacuation system.

2. Impedance Measurement

2.1. Definition

The PMX-4CR12 controller and the PMX-4R24 router are equipped with a loudspeaker line impedance measurement function. This function measures the effective values of the output current and the output voltage. The impedance value of the connected loudspeaker line is calculated by using measured voltage and current. Due to the frequency and temperature dependence of the loudspeaker line, the obtained impedance value can vary substantially. A sinusoidal signal with an appropriate frequency is used for the measurement. The measured value is compared with the reference measurement and a good/bad status is indicated depending on the difference between these two values. If the controller is replaced, the reference measurement must be performed again. The impedance measurement is configured using the IRIS-Net software.

The IMP line supervision method can be used in three different ways:

- Permanent
- Daily
- Triggered via Task Engine block

IMP line supervision does not require any additional components and can be used with any loudspeaker line topology. The entire loudspeaker line circuit, including all cables and loudspeakers, is considered as a single IMP line supervision entity.

Loudspeaker lines in outdoor areas or in areas with high temperature fluctuations, big noise or strong vibrations should not be monitored with impedance measurement.

To detect a line interruption to a single loudspeaker, or the failure of a single loudspeaker, the following instructions must be observed:

- Do not connect more than five loudspeakers to one loudspeaker line.
- All loudspeakers on the loudspeaker line must have the same impedance.
- The tolerance has to be set accordingly.

Notice!

Further information about the IMP measurement method can be found in the controller manual.

2.2. How to setup IMP Measurement

Follow the steps below to set up impedance measurement by using IRIS-Net.:

1. Set the zones which do not require line supervision to "NONE" under column SUPV TYPE. For zones, intended for line supervision, set the SPV TYPE to IMP.
2. Set the measuring frequency to 1000 Hz.
3. Go online with your configuration.
4. Select all zones and start an impedance measurement.

Notice: Zones with an impedance of 30,000 ohms are open (no loudspeaker is connected).
5. Export the line supervision as csv file by pressing the EXPORT button.
6. Open the csv file in Excel and make a rough calculation of the power of the loudspeaker lines:

$$Power(P) = \frac{Voltage^2}{Impedance} = \frac{U^2}{Z} = \frac{(100 V)^2}{Z}$$

7. Compare the calculated power with the planned power.
8. If it is almost the same, continue with the steps on the next page. If it is not, find out why there is such a big difference (e.g. wrong power tapping, wrong/missing loudspeakers, etc.).

The screenshot shows the 'LINE SUPERVISION TABLE' in the PMXCON_1 Configuration software. The table lists 12 speaker outputs (OUT 1 to OUT 12) across 12 zones. The 'SUPV TYPE' column is highlighted in red, showing 'IMP' for zones 1-11 and 'NONE' for zone 12. The 'FREQ [Hz]' column is also highlighted in red, showing '1000 Hz' for all zones. Below the table, the 'LINE MEASUREMENT' section has three buttons: 'SELECT ALL', 'START MEAS', and 'SET REF', all highlighted in red. The 'EXPORT' section has an 'EXPORT' button, also highlighted in red. The 'LINE CONTROL' section shows 'MEASUREMENT PERIOD' set to 'PERMANENT' and 'MEASUREMENT PRIORITY' set to '5'. The 'CCCF LED BEHAVIOUR' section has a checkbox that is unchecked.

SPEAKER OUT	ZONE/LINE NAME	IGNORE	GROUND FAULT	IMP FAULT	SHORT FAULT	EOL FAULT	FREQ [Hz]	LEVEL [V]	IMP-REF [Ohm]	-TOL [%]	+TOL [%]	IMPEDANCE [Ohm]	VOLT [V]	CURRENT [mA]	EOL Q/A	SUPV TYPE
Internal Router (Untitled)																
OUT 1	Zone 1	<input type="checkbox"/>	<input type="checkbox"/>	<input type="checkbox"/>	<input type="checkbox"/>	<input type="checkbox"/>	1000 Hz	0.5 V	0.0 Ω	15 %	15 %	0.0 Ω	0.00 V	0.00 mA	0	IMP
OUT 2	Zone 2	<input type="checkbox"/>	<input type="checkbox"/>	<input type="checkbox"/>	<input type="checkbox"/>	<input type="checkbox"/>	1000 Hz	0.5 V	0.0 Ω	15 %	15 %	0.0 Ω	0.00 V	0.00 mA	0	IMP
OUT 3	Zone 3	<input type="checkbox"/>	<input type="checkbox"/>	<input type="checkbox"/>	<input type="checkbox"/>	<input type="checkbox"/>	1000 Hz	0.5 V	0.0 Ω	15 %	15 %	0.0 Ω	0.00 V	0.00 mA	0	IMP
OUT 4	Zone 4	<input type="checkbox"/>	<input type="checkbox"/>	<input type="checkbox"/>	<input type="checkbox"/>	<input type="checkbox"/>	1000 Hz	0.5 V	0.0 Ω	15 %	15 %	0.0 Ω	0.00 V	0.00 mA	0	IMP
OUT 5	Zone 5	<input type="checkbox"/>	<input type="checkbox"/>	<input type="checkbox"/>	<input type="checkbox"/>	<input type="checkbox"/>	1000 Hz	0.5 V	0.0 Ω	15 %	15 %	0.0 Ω	0.00 V	0.00 mA	0	IMP
OUT 6	Zone 6	<input type="checkbox"/>	<input type="checkbox"/>	<input type="checkbox"/>	<input type="checkbox"/>	<input type="checkbox"/>	1000 Hz	0.5 V	0.0 Ω	15 %	15 %	0.0 Ω	0.00 V	0.00 mA	0	IMP
OUT 7	Zone 7	<input type="checkbox"/>	<input type="checkbox"/>	<input type="checkbox"/>	<input type="checkbox"/>	<input type="checkbox"/>	1000 Hz	0.5 V	0.0 Ω	15 %	15 %	0.0 Ω	0.00 V	0.00 mA	0	IMP
OUT 8	Zone 8	<input type="checkbox"/>	<input type="checkbox"/>	<input type="checkbox"/>	<input type="checkbox"/>	<input type="checkbox"/>	1000 Hz	0.5 V	0.0 Ω	15 %	15 %	0.0 Ω	0.00 V	0.00 mA	0	IMP
OUT 9	Zone 9	<input type="checkbox"/>	<input type="checkbox"/>	<input type="checkbox"/>	<input type="checkbox"/>	<input type="checkbox"/>	1000 Hz	0.5 V	0.0 Ω	15 %	15 %	0.0 Ω	0.00 V	0.00 mA	0	IMP
OUT 10	Zone 10	<input type="checkbox"/>	<input type="checkbox"/>	<input type="checkbox"/>	<input type="checkbox"/>	<input type="checkbox"/>	1000 Hz	0.5 V	0.0 Ω	15 %	15 %	0.0 Ω	0.00 V	0.00 mA	0	IMP
OUT 11	Zone 11	<input type="checkbox"/>	<input type="checkbox"/>	<input type="checkbox"/>	<input type="checkbox"/>	<input type="checkbox"/>	1000 Hz	0.5 V	0.0 Ω	15 %	15 %	0.0 Ω	0.00 V	0.00 mA	0	NONE
OUT 12	Zone 12	<input type="checkbox"/>	<input type="checkbox"/>	<input type="checkbox"/>	<input type="checkbox"/>	<input type="checkbox"/>	1000 Hz	0.5 V	0.0 Ω	15 %	15 %	0.0 Ω	0.00 V	0.00 mA	0	NONE

Picture 1: Setting impedance references

9. Set the measuring frequency back to a lower frequency. The best frequency depends on the used loudspeaker type and its impedance curve. The default measuring frequency is 30 Hz, because it is not audible. If problems occur, you have to check the impedance curve of the loudspeakers.
10. Select again all zones and start an impedance measurement.
11. Set the impedance references (IMP REF).
12. If needed, you can adjust the tolerances.
13. Set the measurement priority according to the project requirements and local norms.

Notice!

If you want to use permanent impedance measurement for an EVAC system according to EN54, you have to give the measurement unit the highest priority below the EVAC state to ensure that the system recognizes line faults within the specified time. Be aware, that background music will be interrupted by the impedance measurement.

14. Select the supervision type NONE for the unused loudspeaker lines. For a better overview it is recommended to check the ignore box for the unused lines.
15. Export the line supervision result as csv file by pressing the EXPORT button. The CSV files can be used for documentation.
16. Save the IRIS-Net file in order to save the reference values.

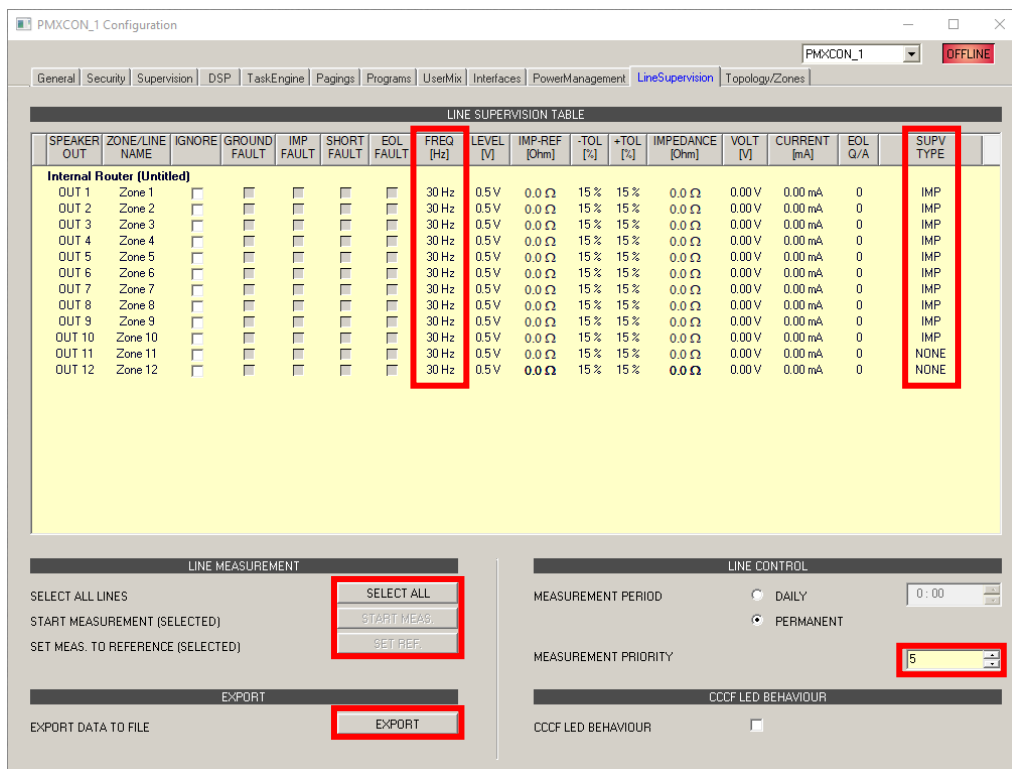

Picture 2: Changing the measurement frequency

Notice!

If you replace hardware (controller/router) or if you remove or add loudspeakers, you have to set a new impedance reference value.

2.3. IMP Troubleshooting

In this chapter you can find possible reasons for IMP problems.

Problem	Possible Reason(s)	Action/Explanation
Impedance increases	Open Circuit Missing loudspeakers	Check loudspeaker cabling and loudspeakers.
Impedance decreases	Short Circuit Loudspeaker network extended	Check loudspeaker cabling. If the line is extended with new loudspeakers or the power tapping of the loudspeakers has changed, you have to set a new reference value.
Small deviations cause error messages, although the loudspeakers are working	Temperature fluctuations A change of the temperature can cause a change of the impedance value Tolerance is too small External vibrations	You are using loudspeakers with the wrong measuring frequency. Check the impedance curve of the loudspeakers to find a flat frequency range. Check if the tolerance value is set correct.
The failure of one single loudspeaker cannot be detected	The tolerance is too big Different loudspeaker types are used on the same line Different power tapping is used on the same line	To detect a line interruption to a single loudspeaker, or the failure of a single loudspeaker, the following instructions must be observed: Do not connect more than five loudspeakers to one loudspeaker line. All loudspeakers on the loudspeaker line must have the same impedance. The tolerance has to be set accordingly.
The IMP line supervision is not working. Even if I disconnect the whole line, it is not recognized by the system.	No reference is set Daily is set as measuring method	Set a reference. The IMP line supervision is only active if a reference is set. If you set daily as measuring method, the line will only be measured once a day. So only once a day the system can recognize if the lines are OK or not.
IRIS-Net shows ground fault or the same low impedance value on many lines.	The measuring system could be damaged.	Please check the loudspeaker lines. Cross cabling and external voltage on the loudspeaker outputs are not allowed. You probably have to exchange the controller/router.

2.4. Tips and Tricks

This chapter describes tips, tricks and hints about IMP line supervision.

Impedance measuring specification

The total impedance connected at the output (loudspeakers and cabling) must be within the specified impedance range in terms of the test frequency (see table below).

Parameter	Value	Default setting (IRIS-Net)
Impedance range	20 – 10000 Ω (corresponds to 500 W to 1 W)	
Impedance tolerance (Accuracy of the measuring mechanism)	6 % \pm 2 Ω	
Frequency range	20 – 4000 Hz	30 Hz
Voltage range	0.1 – 1.0 V	0.5 V

Notice!

There is no need to change the voltage of the IMP measurement. The default value (0.5 V) is the optimum value for the measurement and a low acoustical disturbance.

Impedance measurement values

Below you can find, as example, an impedance curve of a two-way, full-range, 5.25" (133 mm) surface mount speaker. Please keep in mind that the impedance value varies depending on the frequency (see below impedance value @ 40 Hz and @ 1000 Hz).

Frequency response and impedance:

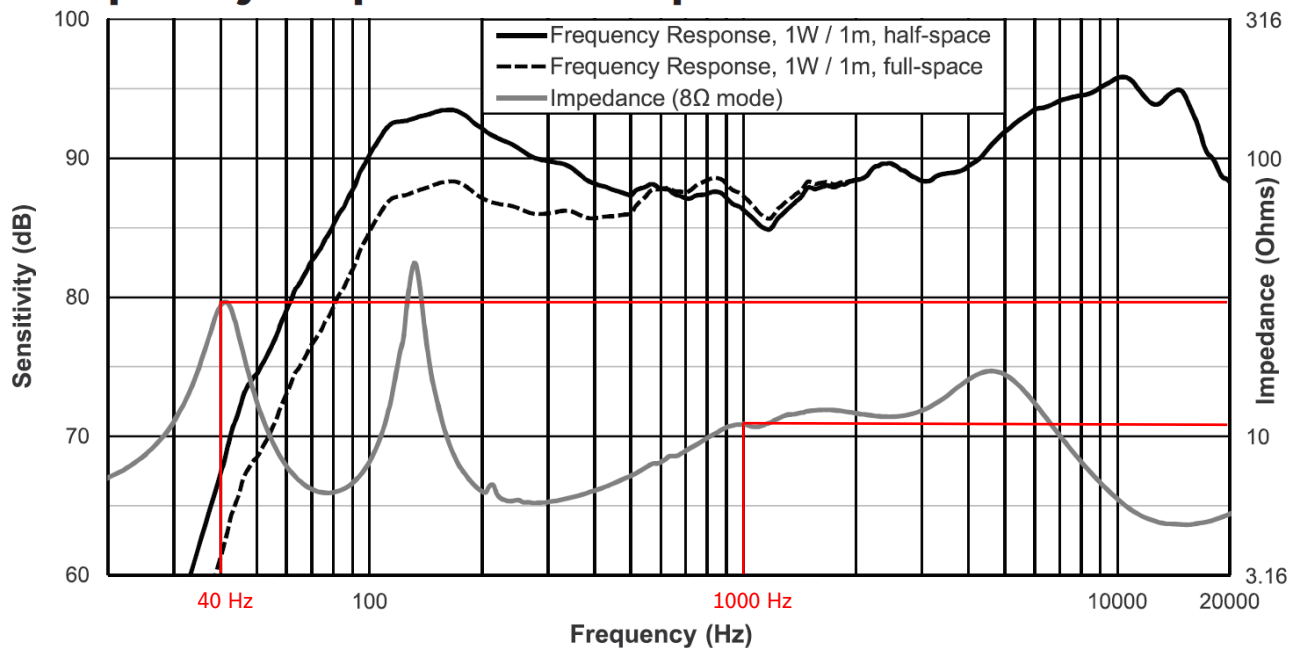

Picture 3: Impedance curve of a two-way full-range surface mount speaker

Loudspeaker cable impedance

The loudspeaker cable impedance can be affected by several negative factors:

- **Ambient temperature:**

The loudspeaker cables, the transformers and the loudspeaker coils are usually made of copper. Copper has a temperature coefficient of $\alpha = 3.9 \text{ 1/K}$.

In other words, the resistance changes by about 4% with a temperature change of 10 °C.

Example:

In a parking garage, the impedance of the loudspeaker cable can change by a factor of about 16% between winter (-10 °C) and summer (+30 °C).

- **Measuring frequency:**

A defective loudspeaker might not be detected if long loudspeaker cables with a higher measuring frequency are used, due to the fact that the cable impedance (or cable capacitance) might become dominant compared to the loudspeaker impedance.

Example:

The impedance value for 20 kHz for a cable with a capacitance value of 100 nF/km and a length of 200 m is about 400 Ω . A 5 W loudspeaker has an impedance of about 2000 Ω . The impedance of the cable including the loudspeakers is about 330 Ω . If the cable is broken near the loudspeaker, the impedance difference is 70 Ω , which is about 21%.

- **Loudspeaker impedance:**

The impedance of the loudspeaker depends on the frequency. The transformers in the loudspeakers have a low impedance value at low frequencies. It is important to ensure that the measurement limits for the specific measurement frequencies are not exceeded, especially for high-power loudspeakers.

Example:

The Sx300PIX loudspeaker has an impedance value of about 110 Ω at 1 kHz, but an impedance value of 50 Ω at 30 Hz.

- **Ground short:**

A ground fault of the loudspeaker cable can affect the impedance measurement of the loudspeaker cable. If a ground fault and an impedance error are displayed simultaneously, the cable ground fault must be corrected first.

3. EOL supervision

3.1. Definition/Description

End-of-line (EOL) technology enables the loudspeaker lines to be monitored for short-circuit and interruptions. The EOL modules can be used for permanent supervision for loudspeaker lines with or without permanent background music or if passive volume controls are used. Please be aware that the volume control has to be placed after the EOL board, inside the loudspeaker and needs a bypass relay, otherwise the pilot tone level will be affected.

The EOL line supervision requires an addressable digital EOL 8001 module, connected to each outer end of a loudspeaker line. EOL master units are integrated as factory default in each PMX-4CR12 controller or PMX-4R24 router.

A single EOL 8001 module ensures full supervision of the signal path from a loudspeaker output to the module. An IMP measurement is triggered automatically after an EOL fault. Thus an impedance reference has to be set upfront. Shorted or broken loudspeaker lines are reported within a pre-defined time (100s according to EN54). Individual loudspeaker faults cannot be detected.

Method of operation

An EOL slave module EOL 8001 is installed at the end of the loudspeaker line. The loudspeaker line is used for both, the power supply of the module (via the non-audible pilot tone) and for bidirectional communication between the EOL master in the output stage of the controller or router and the EOL slave module (using very low-frequency signals and a ground connection). If a communication error occurs – for example, if the EOL master does not receive a response from the slave – an error message is generated. The unique addressing of the slave modules per device (controller/router), means that multiple slave modules can be connected to one loudspeaker line.

Communication

For communication between the master and the slave modules, the EOL slave modules must be connected to ground. The shielding on the loudspeaker cable, a free wire in the loudspeaker cable, or any other available ground point – such as the safety ground of the power supply system – can be used for this purpose (most of the time the drain wire of the loudspeaker cable is used). The resistance R_G between a loudspeaker line and ground must be above a certain value (see EOL 8001 manual). The capacitance C_G between a loudspeaker and the ground must not be greater than a certain value (see EOL 8001 manual).

Notice!

Depending on the installation, a loudspeaker line with EOL modules can be in parallel with other EOL modules on other loudspeaker lines. The capacitance of parallel connected loudspeaker lines must be summed to determine the total capacitance C_G that one EOL Master can drive. Make sure the worst case situation does not exceed the maximum allowed capacitance. It is recommended to connect not more than one router board (= 2 router clusters with in total 12 outputs) to one amplifier channel.

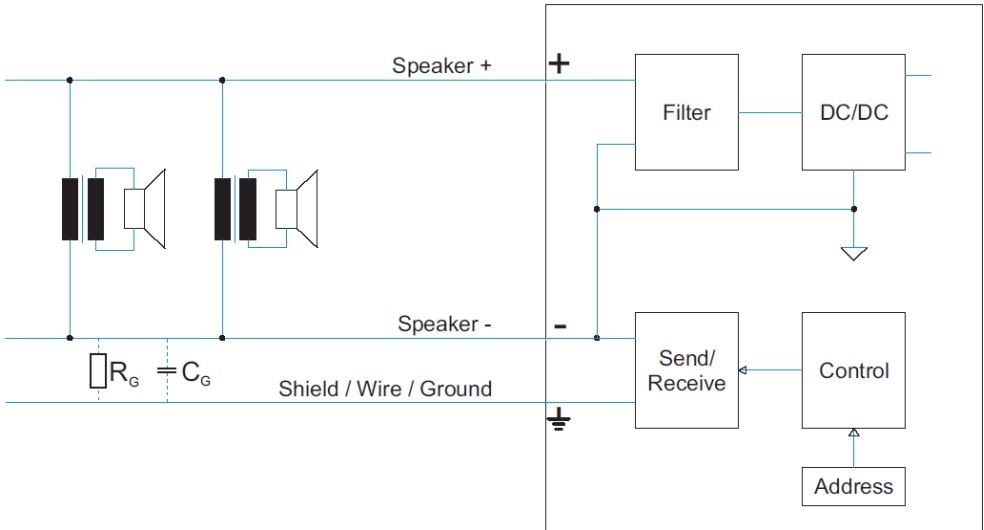

Picture 4: Circuit diagram (R_G and C_G caused by the loudspeaker installation, e.g. cable type, length)

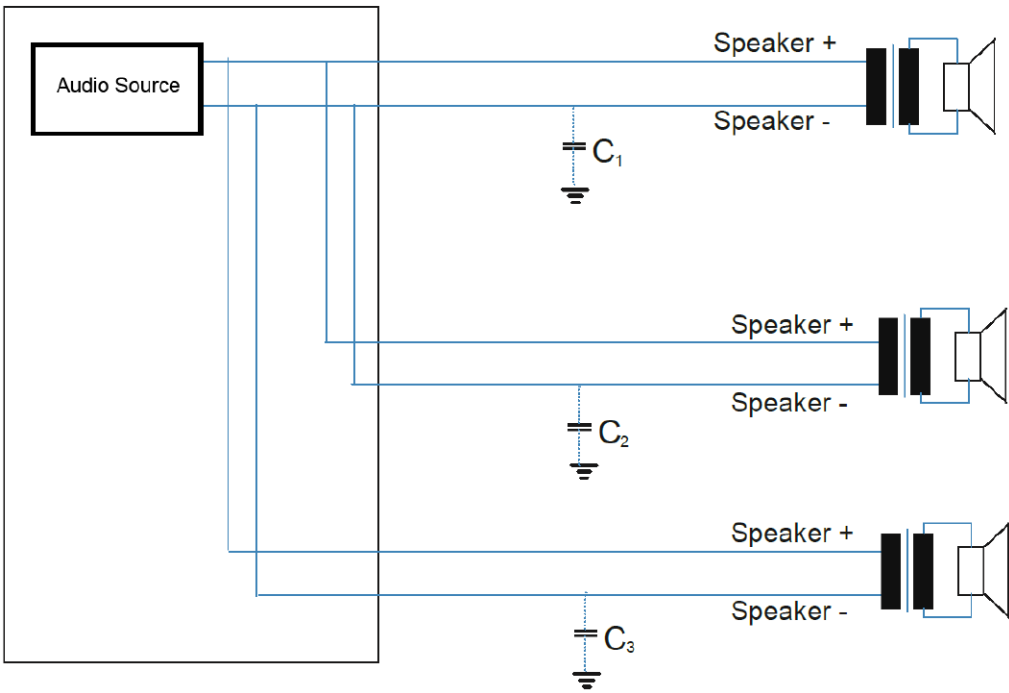

Picture 5: Wiring diagram $C_G = C_1 + C_2 + C_3$

Notice!
 The loudspeaker can also have an influence on the capacitance, if the impedance of the loudspeaker drops significantly in the high frequency range.

3.2. How to setup EOL Supervision?

Follow the steps below to set up EOL line supervision:

1. Set the address on the modules using the DIP switches and connect the modules to the loudspeaker lines and ground. Each module must have a unique address and the maximum amount of modules connected to one EOL master has to be considered.
2. Configure the EOL modules in IRIS-Net according to your project.
3. Go online.
4. Start with the approach “How to setup IMP measurement?” described in the IMP measurement part.
5. Check if all EOL modules are recognized. If not, go to the next page (troubleshooting).
6. To test, if all EOL modules are correctly configured and wired, disconnect each line one by one and check if the fault is recognized and displayed correctly.

Notice!

The EOL modules must be installed in a housing (inside the loudspeaker or external housing) and should be easily accessible. An up-to-date documentation with the location of the EOL modules should be available.

3.3. EOL Troubleshooting

In this chapter you can find possible reasons for error messages. The main problem is that the EOL master does not get a response from the EOL slave module. Please check always the idle mode and the active signal mode.

idle mode = no signal is active on the loudspeaker line

active mode = signal is active on the loudspeaker line

Problem	Possible Reason(s)	Action/Explanation
EOL module is not detected	<p>No power supply on the EOL boards</p> <p>The voltage drop is too big (e.g. caused by loudspeaker lines)</p> <p>Pilot tone generator overload caused by too big loudspeaker load</p>	<p>Activate with the DIP switch S2-4 a LED and check if the module is power supplied. If the LED is not flashing, there is not enough power for the module (pilot tone level is too low).</p> <p>Check the loudspeaker load. Load above the specification (500W / 20Ω) will produce high voltage drop on the internal output impedance of the pilot tone generator or can activate the limiter in the amplifier.</p> <p>Check the voltage drop on the wires. If it is above 10 % use thicker cables.</p> <p>Check the pilot tone level on the EOL board between pin 1 and 2 (The voltage measurement device must be able to measure up to 25kHz). The voltage should not be below 8V_{eff}. Check the configuration of the pilot tone voltage in idle and active mode in IRIS-Net:</p> <p>Idle mode: Modify Properties: Routerboard.EOL.Level, EOLLevelAB and EOLLevelCD (default: 10 V_{RMS})</p> <p>Active signal mode: DSP -> Advanced properties of the output section (default: -14,6 dBu)</p> <p>Please check if the pilot tone is present at the amplifier input of the controller. If not, check the wiring between controller and amplifier.</p> <p>Notice! In chapter 6 you can find more information about measuring the pilot tone level.</p>
No communication between EOL master and EOL slave	Below minimum R _G	<p>The R_G between loudspeaker lines and ground will influence the communication. Depending on the EOL board version the R_G must be above a certain value (see EOL 8001 manual).</p> <p>Measure R_G between loudspeaker line and ground. If the value is below the limit, check the wiring.</p>

Problem	Possible Reason(s)	Action/Explanation
No communication with the EOL boards	The slave modules are not connected to ground	<p>Ground connection is needed for communication. Please ensure, that all slave modules are connected to ground.</p> <p>Measure the connection of the EOL board from pin 3 of the connector to ground and measure the connection of the controller / router (grounding screw) to ground. The value of both measurements must be below 1 kΩ.</p>
No communication with the EOL boards	Ground Fault	<p>A ground fault will prohibit the communication between EOL master and EOL board.</p> <p>You have to remove the ground fault.</p>
No communication between EOL master and EOL slave	Above maximum C_G	<p>The C_G between loudspeaker line and ground can influence the communication. C_G depends mostly on the used cable. Depending on the EOL board version the C_G must be above a certain value (see EOL 8001 manual).</p> <p>Make sure, that the capacitance of parallel-connected loudspeaker lines do not exceed the maximum allowed capacitance.</p> <p>Use a test EOL module to check if the module can be found, when connected directly to the output of controller/router without the long loudspeaker cable.</p> <p>Afterwards connect the EOL module together with the long cable to the output. If the problem is still present, you have probably a capacitance issue. You have the following possibilities to reduce C_G:</p> <ol style="list-style-type: none"> 1. Use a different cable 2. Do not use wires in parallel 3. Use newer EOL boards with higher maximum C_G values 4. Use even or odd EOL board addresses 5. Use one amplifier channel for max. two router clusters
EOL faults in active signal mode	Mixed line supervision types	<p>If some lines are supervised by IMP permanent and some by EOL, the signal and also the pilot tone will be interrupted for the IMP measurement, if they are sharing the same audio signal or to be more precise, the same amplifier channel.</p> <p>Solution: Do not use mixed line supervision types for the same audio signal. It is always recommended to use one type of supervision for the whole system.</p>

Problem	Possible Reason(s)	Action/Explanation
Short circuit is not recognized by the system	No IMP reference is set	You have to set an IMP reference to activate the IMP measurement, otherwise the system cannot check if the measured value is OK or not.
One or more EOL boards do not answer	Wrong address on the EOL boards	Check the EOL board's address on the module and also in IRIS-Net.
PG / LT Temperature fault	The pilot tone generator could be overloaded	Measure the voltage at the EOL modules as described in chapter 6. If it is high enough, try to lower the voltage of the pilot tone generator: Controller: Modify Properties -> Routerboard.EOL.Level Router: Modify Properties -> EOLLevelAB and EOLLevelCD

Check the installation with the LED on the module

Use the LED on the module to check the connection to the line and earth:

1. Activate the LED for five minutes by setting switch 4 on DIP switch S2 to OFF and back to ON.
2. Use the following table to check the status of the installation

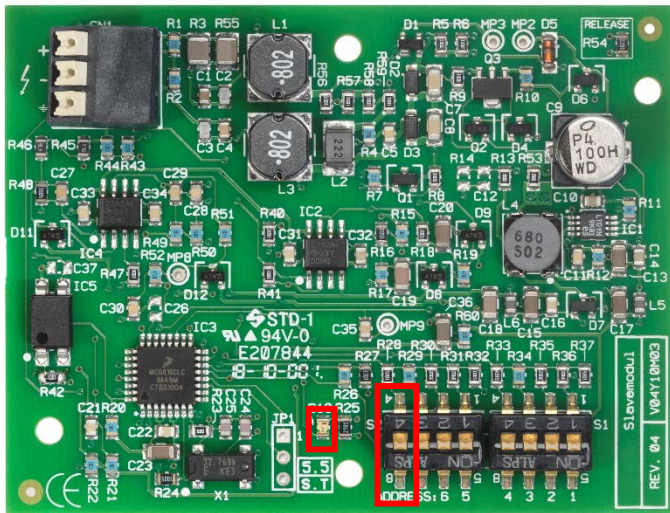

Picture 6: EOL 8001 board

Status LED	Description
OFF	No voltage supply
Slow flashing (2 Hz)	Correct power supply (pilot tone is on the loudspeaker line). Module is ready.
Rapid flashing (10 Hz), every 40 seconds	A valid command is being received from the EOL master. This indicates a good ground connection.

Module address and quantity

The module address must be unique within each zone topology (each controller, router). The maximum amount of modules can be found below.

The following values must not be exceeded:

- Max. 30 modules / zone
- Max. 60 modules / controller
- Max. 60 modules / router
- Max. 500 modules / single system
- Max. n*500 modules in total in a networked system with n controllers (n_{max} = 4)

Notice!

The maximum amount of modules also depends on Hardware and Software version. So if you are using old Hardware and old Software, please check the EOL 8001 board manual.

Maximum allowed capacitance C_G of hardware and software

The maximum C_G (loudspeaker wire to ground/earth) depends on the firmware version of the EOL module and the firmware version of Controller and Router.

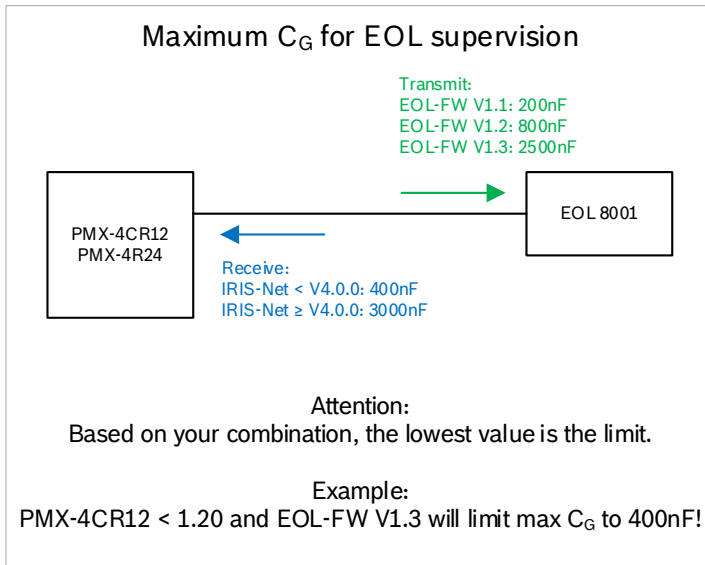

Maximum capacitance C_G of the loudspeaker cable

Only very few cable manufactures specify the maximum C_G (wire to shielding) in the data sheets. Please find below some examples*:

Cable type	Diameter [mm]	Crosssection [mm ²]	Pairs [n]	C_G [nF/1km]
shielded	0,8	0,50	1	500
shielded	1,4	1,54	1	750
shielded	2,0	3,14	1	1000
shielded	0,8	0,50	2	400
shielded	1,4	1,54	2	500
shielded	2,0	3,14	2	600
shielded	0,8	0,50	4	320
shielded	1,4	1,54	4	338
shielded	2,0	3,14	4	375

* These are just some examples. The values can vary from manufacturer to manufacturer.

Most cable manufactures specify the capacitance C_B (wire to wire). The following rule of thumb can help to estimate:

$$C_G = 4 \times C_B \text{ (the real value will be about 5\% - 10\% lower)}$$

C_G : Capacitance wire to shielding/ground

C_B : Capacitance wire to wire

Example:

C_B is defined in the datasheet with 120nF/km -> C_G is about 480nF/km.

In the case of a multicore cable, the cable manufacturer often specifies only the C_b for the "worst case" with one pair of wires. In reality, each additional pair of wires reduces C_G by about 20%.

1 x 2 x 0.8	C_B : 125nF/km	C_G : 500nF/km	for one pair
2 x 2 x 0.8		C_G : 400nF/km	(-20% of 500nF) for one pair
4 x 2 x 0.8		C_G : 320nF/km	(-20% of 400nF) for one pair
8 x 2 x 0.8		C_G : 256nF/km	(-20% of 320nF) for one pair

A multicore cable helps to lower C_G . A multicore cable 8 x 2 x 0.8 has 8 x 256nF = 2048nF. Eight cables with 1 x 2 x 0.8 have 8 x 500nF = 4000nF.

Notice!

For mixed cables, the cable with the highest C_G should be used for simple calculation.

Calculation Example

The maximum cable length for the controller (12 zones with 1 amplifier channel) or for the router (24 zones with 1 amplifier channel) can be calculated as follows:

IRIS-Net version: 3000 nF (IRIS-Net 4.0)
 EOL version: 2500 nF (EOL-FW 1.3)

 Lowest value: 2500 nF
 Cable Specs: 320 nF/km (C_G per wire pair of a 4x2x0,8 mm shielded cable)

 Result: $Total\ length\ of\ loudspeaker\ lines\ per\ device = \frac{2500\ nF}{320\ nF/km} = 7,8\ km$

So in this example the controller can work with 650 m on every zone and the router can work with 325 m on every zone.

 Requirement 1: 20 loudspeaker lines with each 500 m need to be connected to the router. How to realize that?

 Solution: You can add a second amplifier channel for the router to double the distance (625 m per zone). However, it will only bring an improvement if the amplifier channels are assigned like this:

Amplifier channel 1: zone 1-12 can work with 7,8 km
 Amplifier channel 2: zone 13-24 can work with 7,8 km

Notice!
 Adding more amplifier channels to the router will not bring an improvement.

 Requirement 2: One loudspeaker line with about 800 m needs to be connected to the controller. How to realize that?

 Solution: The total length of loudspeaker lines of the controller is in this case 7,8 km. So one loudspeaker line with a length of 800 is acceptable, as long as the other lines are correspondingly shorter. Adding a second amplifier to the controller will not increase C_G . So only using another cable with a lower C_G can help to increase the distance. Another option would be to move some lines of the controller to the router.

4. PEOL supervision

4.1. Definition/Description

The Plena End-of-Line boards can be used for permanent supervision on loudspeaker lines. The PLN-1EOL module can be used, e.g. for loudspeaker lines with or without permanent background music or if passive volume controls are used. Please be aware that the volume control has to be placed after the PEOL board, inside the loudspeaker and needs a bypass relay.

Plena End-of-Line boards PLN-1EOL monitor the presence of a pilot tone on a loudspeaker line. The board is placed either at the end of a loudspeaker line or in the rack and detects the pilot tone signal. This signal is always present on the line: when back ground music (BGM) is playing, when a call is in progress or when no signal is present. The pilot tone is inaudible and at a very low level. When the pilot tone signal is present, a LED on the board lights up, and a contact on the board is closed. When the pilot tone fails, the contact opens, and the LED goes off.

If mounted at the end of the loudspeaker line, this applies to the integrity of the whole line. Shorted or broken loudspeaker lines are reported within a pre-defined time and an IMP measurement is triggered automatically. Thus a loudspeaker line impedance reference has to be set upfront. Individual Loudspeaker faults cannot be detected.

The presence of the pilot tone signal does not depend on the number of loudspeakers on the line, the load on the line, or the line capacitance. The contact can be used to detect and report faults on a loudspeaker line.

Several EOL boards can be daisy-chained to a single fault input. This allows a loudspeaker line with several branches to be monitored. Daisy chaining of PEOL modules can only be used within one alarm area.

Background music will not be interrupted, because also the background music includes a pilot tone signal.

4.2. How to setup PEOL Supervision

Follow the steps below to set up PEOL line supervision:

1. Choose one of the options below and wire and place the modules as described below.
2. Configure the PEOL modules in IRIS-Net according to your project.
3. Go online.
4. Start with the approach “How to setup IMP Measurement” described in the IMP part
5. Check if all PEOL modules are recognized. If not, go to the next page (troubleshooting).
6. Disconnect the lines one by one and check if the fault is recognized and displayed correctly.

Notice!

The PEOL modules must be installed in a housing (loudspeaker or external housing) or in the rack and should be easily accessible. An up-to-date documentation with the location of the PEOL modules should be available.

The PEOL modules can be installed in four different ways:

Option 1: Single board connection with FAULT MONITOR

- Module is placed at the “dead end” of a loudspeaker line, either within a loudspeaker housing or within a separate installation box
- Module has to be connected to loudspeaker line hot (+) and cold (-) wires
- Set the jumper JP1 as shown below (resistors are active)
- One normally closed fault-reporting contact has to be connected to a controller or a router GPI-S (supervised input) via a separate control line.
- Activate the FAULT MONITOR in the Interfaces tab of the controller and set the values for the ACTIVE and the OK range

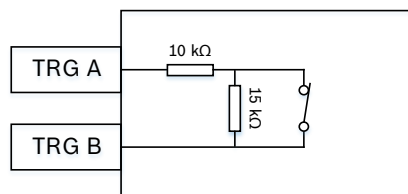
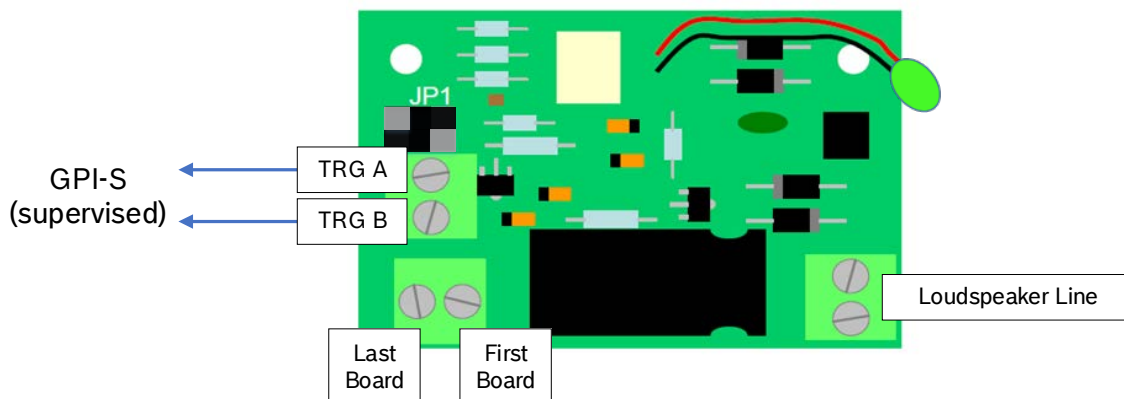

Option 2: Daisy chain connection with FAULT MONITOR

- The modules have to be placed at each “dead end” of a loudspeaker line, either within a loudspeaker housing or within a separate installation box
- Module has to be connected to loudspeaker line hot (+) and cold (-) wires
- Set the jumpers JP1 as shown below
- A 20 kΩ or 22 kΩ resistor has to be placed in parallel to the PEOL modules
- Several daisy-chained, normally closed, fault-reporting contacts have to be connected to a controller or a router GPI-S (supervised input) via a separate control line.
- Activate the FAULT MONITOR in the Interfaces tab of the controller and set the values for the ACTIVE and the OK range

Notice!

EOL modules of different alarm areas must not be daisy-chained and thus not share the same control input. It is recommended, that a maximum of 6 line outputs share the same control input.

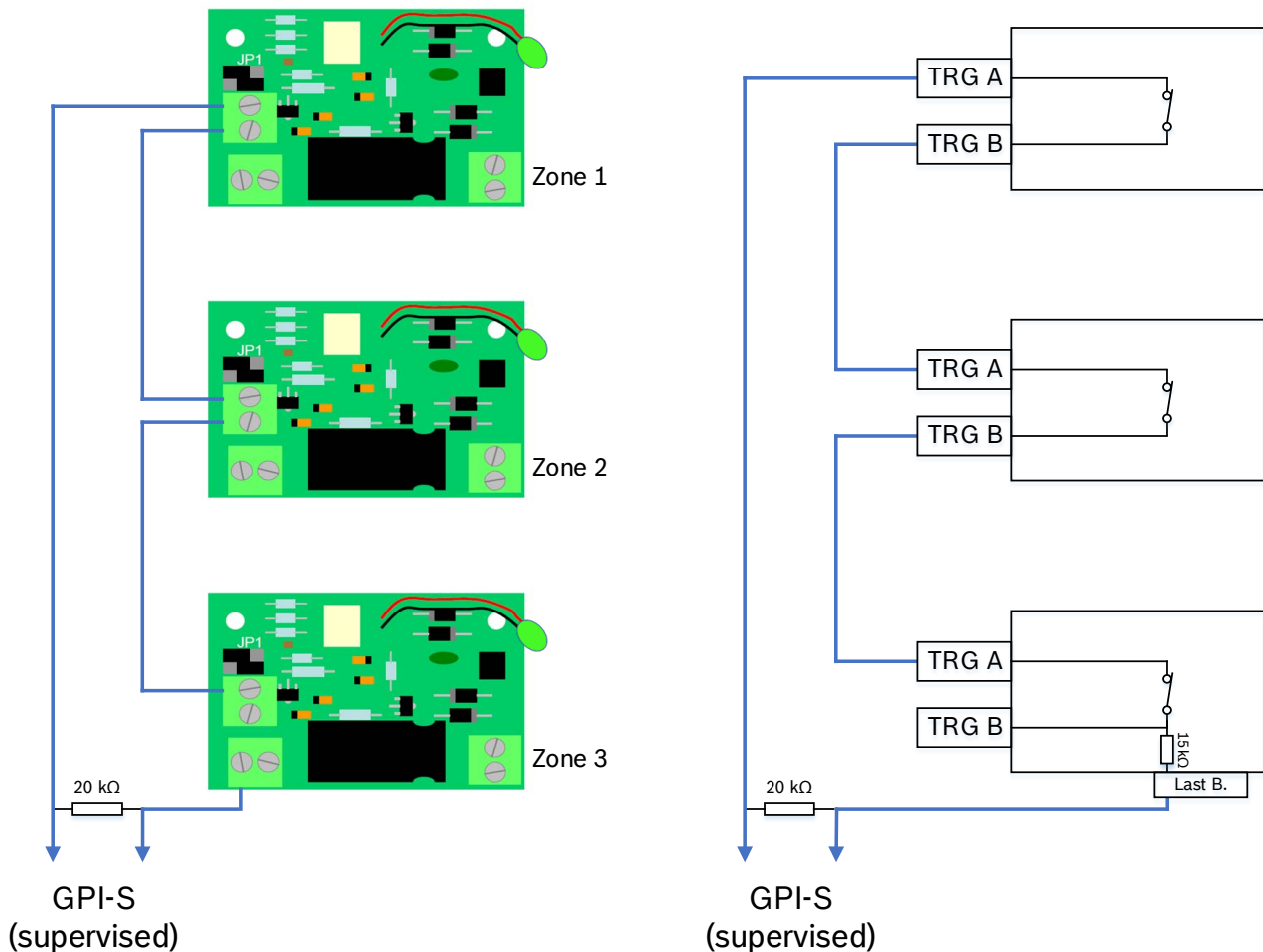

Option 3: Single board connection without FAULT MONITOR

- Module is placed at the “dead end” of a loudspeaker line in the same rack than the controller and routers
- You need a 100V feedback line from the last loudspeaker to the rack/cabinet
- Module has to be connected to loudspeaker line hot (+) and cold (-) wires
- Set the jumper JP1 as shown below (resistors are active)
- One normally closed fault-reporting contact has to be connected to a controller or a router GPI-I or GPI-S (digital input) via a separate control line.

Notice!

GPI-S is connected to ground, but GPI-I needs an extra power supply.

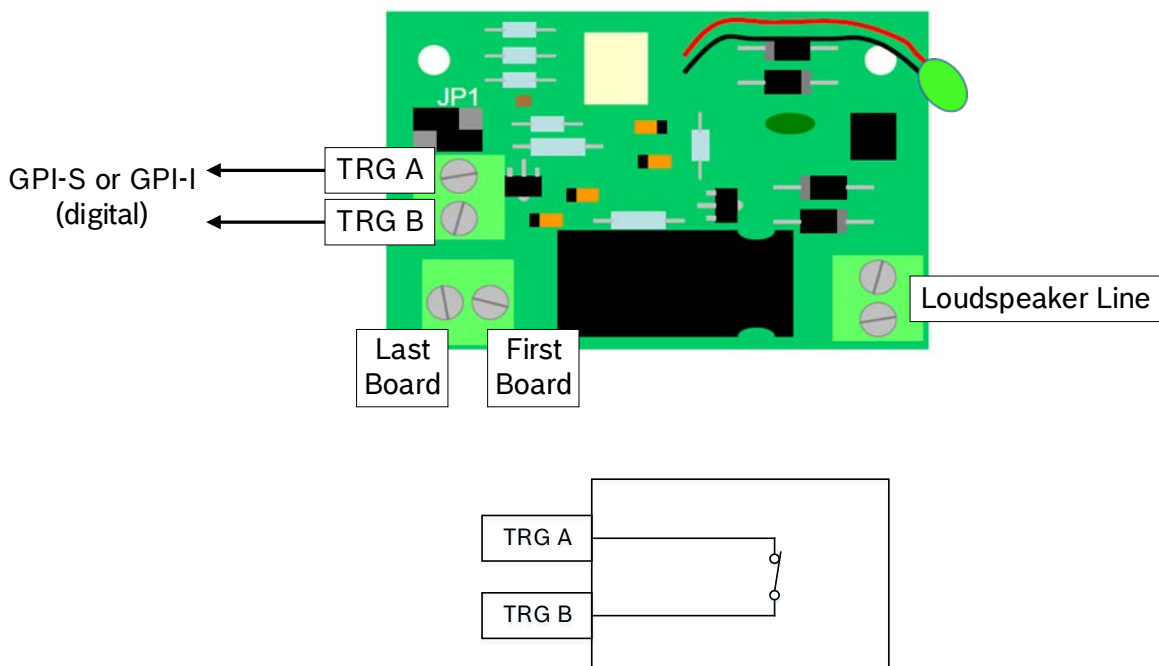

Option 4: Daisy chain connection without FAULT MONITOR

- The modules have to be placed at each “dead end” of a loudspeaker line in the same rack than the controller and routers
- You need a 100V feedback line from the last loudspeaker to the rack/cabinet
- The modules have to be connected to loudspeaker line hot (+) and cold (-) wires
- Set the jumpers JP1 as shown below
- Several daisy-chained, normally closed, fault-reporting contacts have to be connected to GPI-I or GPI-S (digital input) via a separate control line.

Notice!

GPI-S is connected to ground, but GPI-I needs an extra power supply.

EOL modules of different alarm areas must not be daisy-chained and thus not share the same control input. It is recommended, that a maximum of 6 line outputs share the same control input.

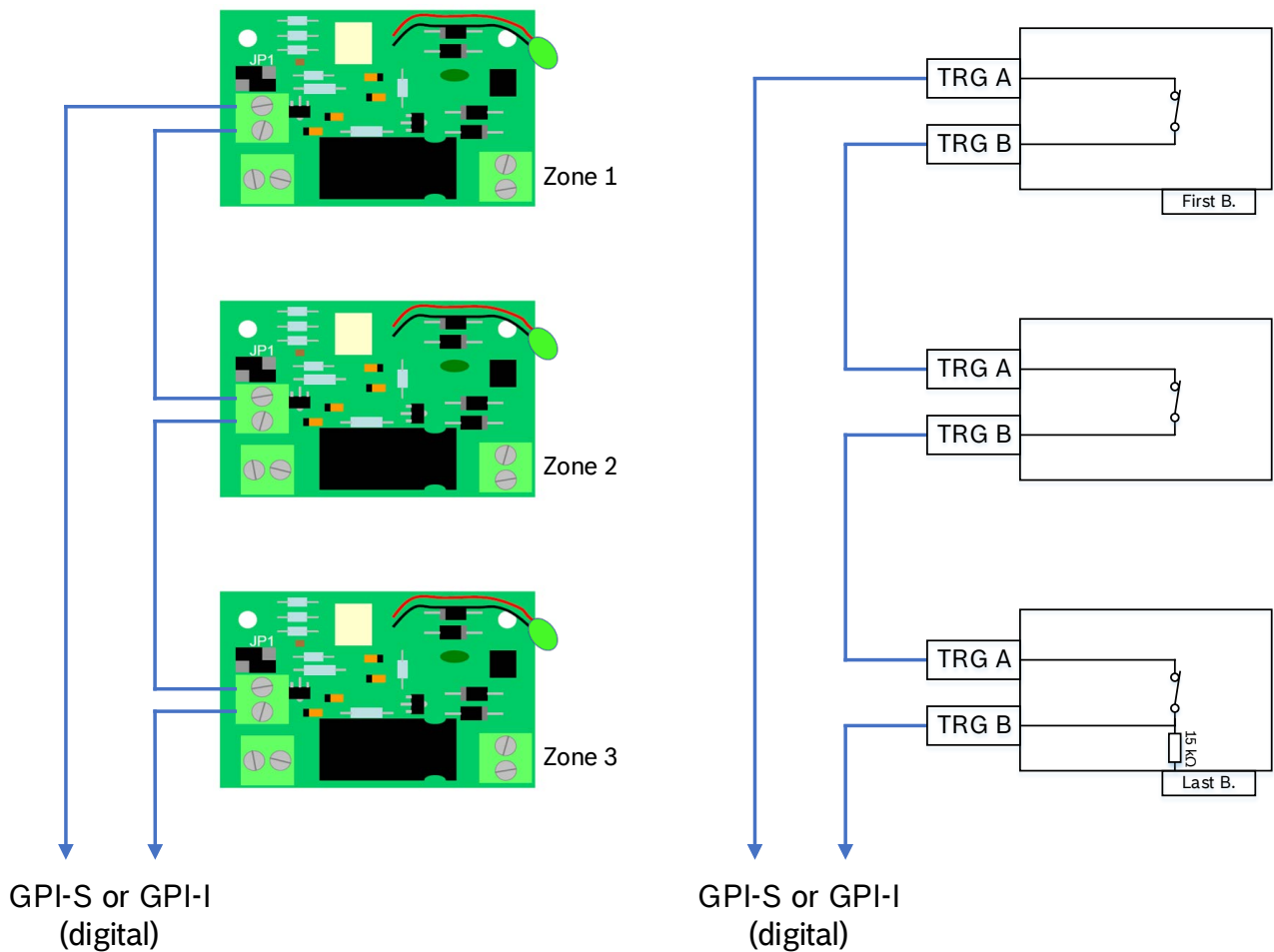

4.3. PEOL Troubleshooting

In this chapter you can find possible reasons for error messages.

Problem	Possible Reason(s)	Action/Explanation
<p>No power supply on the PEOL boards</p>	<p>The voltage drop is too big</p> <p>Loudspeaker overload</p> <p>Short Circuit</p> <p>Open Circuit</p>	<p>If the LED is not illuminated, there is not enough power for the module.</p> <p>Check the voltage drop on the wires. If it is above 10 %, use thicker cables.</p> <p>Check the loudspeaker load. Load above the specification (500W / 20Ω) will produce to high voltage drop on the internal output impedance of the pilot tone generator or can activate the limiter in the amplifier.</p> <p>Check the pilot tone level on the EOL board (100 V input). The voltage measurement device must be able to measure up to 25kHz. The voltage should not be below 5V @ 20 kHz. Check the configuration of the pilot tone voltage in idle and active mode in IRIS-Net:</p> <p>Idle mode: Routerboard.EOL.Level, EOLLevelAB and EOLLevelCD</p> <p>Active signal mode: DSP -> Advanced properties of the output section</p> <p>Notice! In chapter 6 you can find more information about measuring the pilot tone level.</p>
<p>LED is not synched with the contact</p>	<p>LED threshold and switch threshold may be slightly different.</p>	<p>You have reached the threshold. So check the voltage drop on the wires. If it is above 10 % use thicker cables.</p> <p>Check the loudspeaker load. Load above the specification (500W / 20Ω) will produce to high voltage drop on the internal output impedance of the pilot tone generator or can activate the limiter in the amplifier.</p> <p>Check the pilot tone level on the EOL board.</p> <p>Notice! In chapter 6 you can find more information about measuring the pilot tone level.</p>

Problem	Possible Reason(s)	Action/Explanation
<p>Fault reporting is not correct</p>	<p>Jumper is not set correct</p> <p>Fault monitoring is active/inactive</p> <p>Wrong settings in the interfaces tab</p> <p>The modules are not isolated</p>	<p>Check if the jumpers of JP1 are set correct.</p> <p>The Fault Monitoring on the interface tab of the controller should only be active if needed (version 1-2).</p> <p>The voltage ranges (active and OK) have to be set correct. Check the voltage of the different situations (short circuit, open circuit, OK, Active) and set the range accordingly.</p> <p>The modules have to be mounted isolated. Be careful, that the pins on the bottom side of the board are not shorted.</p>
<p>PG / LT Temperature fault</p>	<p>The pilot tone generator could be overloaded</p>	<p>Measure the voltage at the PEOL modules as described in chapter 6. If it is high enough, try to lower the voltage of the pilot tone generator:</p> <p>Controller: Modify Properties -> Routerboard.EOL.Level</p> <p>Router: Modify Properties -> EOLLevelAB and EOLLevelCD</p>

4.4. Tips and Tricks

This chapter describes tips, tricks and hints about PEOL supervision.

Check the installation with the LED on the module

Use the LED on the module to check the presence of the pilot tone and the state of the contact.

Status LED*	Description
ON	Voltage supply, contact closed
OFF	No voltage supply, contact open

* LED threshold and switch threshold may be slightly different.

PEOL quantity and recommendation

EOL modules of different alarm areas should not be daisy-chained and thus not share the same control input. It is recommended, that not more than 6 loudspeaker line outputs (one cluster) share the same control input.

The following values must not be exceeded:

- Max. 30 modules / zone
- Max. 30 modules / controller
- Max. 30 modules / router
- Max. 500 modules / single system
- Max. $n \cdot 500$ modules in total in a networked system with n controllers ($n_{\max} = 4$)

5. Combination of Line Supervision Methods

The combination of line supervision methods can lead to severe limitations and problems. Therefore, it is recommended to use only one line supervision type for the entire system.

Notice!

IRIS-Net does not prevent the combination of different line supervision methods.

6. Pilot Tone

The router and the controller contain pilot tone generators and pilot tone amplifiers, which can be provided to the loudspeaker zones. The pilot tone generators are configured using the IRIS-Net Software.

Under certain conditions (e.g. high signal level or loudspeakers with high sensitivity in the high frequency range) it may be possible that people can hear the pilot tone. In this case, increase the frequency of the pilot tone and/or decrease the pilot tone level.

How to adjust the pilot tone level in the IRIS-Net software

You can adjust the pilot tone level (idle and active signal mode) in the IRIS-Net configuration. But do not misuse these settings to compensate a too large voltage drop. The voltage degradation over cables should be 10 % maximum.

To set the pilot tone for idle mode:

Right click on the controller -> modify properties

Controller -> Routerboard.EOL.Level (should be 10 V_{RMS})

Router -> EOLLevelAB and EOLLevelCD (should be 10 V_{RMS})

To set the pilot tone for active signal mode:

Controller -> DSP -> Right click on the output section -> Advanced Control (should be -14,6 dBu)

Parameter	Value/Range
Generator status	On/Off
Signal frequency	18000-21500 Hz
Signal amplitude (depends on load)	1-10 V

How to measure the pilot tone level on an EOL/PEOL board

You can either do an AC measurement of the pilot tone or a DC measurement beyond the AC/DC converter. The AC measurement requires a voltmeter, that can measure up to 25 kHz.

EOL

AC_{RMS} at the input of the module (pin + and -):

min. 8 V_{RMS}

max. 12 V_{RMS}

DC measurement @ MP3 and MP2:

min. 12 V

max. 24 V

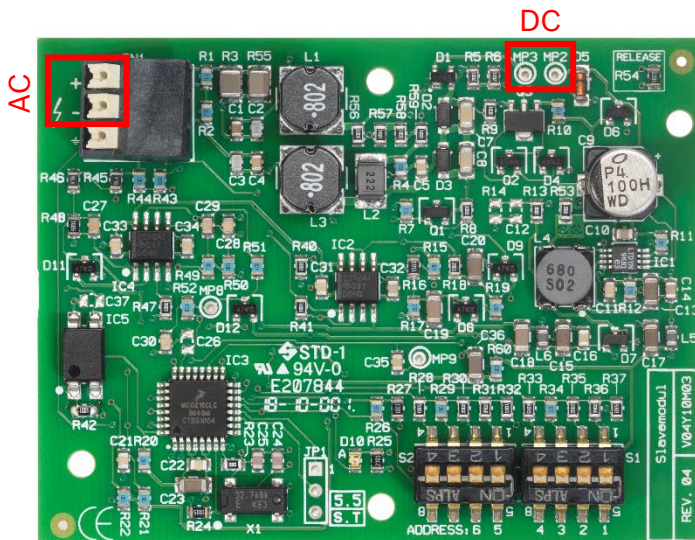

PEOL

AC _{RMS} at the input of the module:	min. 5 V _{RMS}	max. 12 V _{RMS}
DC measurement in parallel to the 220 μF ELKO:	min. 4 V	max. 9 V

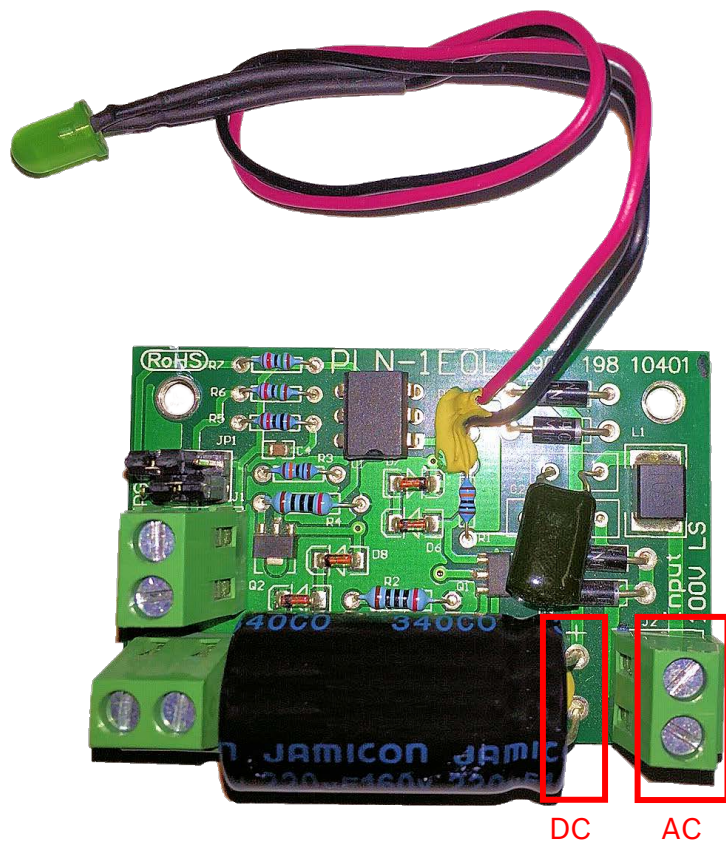

Notice!

Do not increase the pilot tone level in the IRIS-Net software above 12 V_{RMS} for the idle mode and not above -13 dBu (12 V_{RMS} on the loudspeaker line) for the active signal mode. Above these levels the sine wave is no longer a sine wave and the distortions are audible on the loudspeakers.

7. Ground Fault Supervision

Due to general personal safety rules, which vary from country to country, 70V/100V loudspeaker lines have to be isolated from ground.

Every PMX-4CR12 controller or PMX-4R24 router has an internal measuring system for permanent ground fault supervision. If the resistance between common electrical earth and any loudspeaker line wire drops below 50 k Ω , the controller or router detects it, and a ground fault is reported.

Ground fault and the different line supervision methods

Ground fault detection is obligatory and cannot be disabled, no matter which type of line supervision type is used.

If a ground fault occurs in an EOL/PEOL supervised line, more than one line can be affected. In Idle mode all lines of a router board are connected to the same EOL master and also pilot tone generator/amplifier. Therefore, if one line has a ground fault, all lines display ground fault. By manually starting an impedance measurement in each single line, you can find out which line has the ground fault. The measured line will be separated from the others and it will be displayed for a short time if this line has a ground fault or not.

The same is applicable for the active signal mode. Therefore, if one line has a ground fault, all lines connected in parallel display ground fault, because the lines are interconnected via the amplifier.

When using IMP measurement, only the line having the ground fault displays ground fault.

8. Line Supervision and In-Line Volume Control

In-line volume controls reduce signal level, this way also affecting line supervision test signals and pilot tone.

In combination with impedance measurement the volume controls can be bypassed temporarily during the loudspeaker line impedance measurements. So each volume control needs a priority relay to bypass the volume control. Regardless of whether the volume control is mounted at the beginning of a line and can control the whole line or the volume control is included in the loudspeaker cabinet, a priority relay is always needed.

In-line volume control in combination with EOL/PEOL line supervision is only possible, if the volume control is placed after the EOL/PEOL board, directly in the loudspeaker cabinet. If the volume control is mounted at the beginning of the line, it will also reduce the pilot tone level and you will get EOL/PEOL errors. Additionally each volume control needs a priority relay to bypass the volume control, if an IMP measurement is started after an EOL/PEOL fault or if an alarm is started.

Conclusion:

Impedance measurement supervision requires volume controls with volume override functionality, and EOL/PEOL supervision type can be used, if volume controls are included in the loudspeaker and after the modules.

Notice!

In-Line volume control is not allowed to be used in EN54-16 certified systems, independent of the line supervision method. An exception to this are zones which are not used for evacuation or inactive in alarm mode.

9. Loudspeaker Cables

The voltage drop over cables should not exceed 10 %.

Cables with higher voltage drop lead to a high proportional cable attenuation at the loudspeakers. This is particularly noticeable at higher volume levels, for example alarm signals. A high voltage drop can also cause communication problems with the EOL modules. The following table gives an overview of the maximum cable lengths for different speaker loads depending on the cable diameters.

Cross Section [mm ²]	Diameter [mm]	10 W [m]	20 W [m]	100 W [m]	200 W [m]	300 W [m]	400 W [m]	500 W [m]
0.5	0.8	1000	800	160	80	53	40	32
0.75	1.0	1000	1000	240	120	80	60	48
1.0	1.1	1000	1000	320	160	107	80	64
1.5	1.4	1000	1000	480	240	160	120	96
2.5	1.8	1000	1000	800	400	267	200	100
4.0	2.3	1000	1000	1000	640	427	320	256

Maximum loudspeaker load

The maximum rated power should not exceed 500 W for each amplifier and/or controller/router output (= one loudspeaker output).

Loudspeaker wiring faults:

Loudspeaker cables, which typically run through the entire building, are more sensitive to wiring faults.

There are different types of wiring faults as mentioned below:

- **Ground fault:** If the resistance between ground and speaker wire is < 50kΩ, a ground fault is indicated.
- **Short circuit or open line:** A cable that is short-circuited or open is detected by the built-in impedance measurement, if the reference values are set correctly.
- **Swapped zones:** Swapped zones cannot be found/detected by impedance measurement, if they have approximately the same load.
- **Single pole connections between two zones:** Single-pole connections lead to increased crosstalk when one of the zones becomes active and/or when both zones distribute a different signal. This results in incorrect impedance values being measured. This fault cannot be detected by the ground fault detection and/or impedance measurement.
- **Parallel connection of two or more zones:** In this case two amplifier channels with different signals or one amplifier channel and the impedance measurement can be connected in parallel. This fault cannot be detected by the ground fault supervision and/or impedance measurement, as the impedance reference values may already have been set incorrectly.
- **Crossed zones:** A wire from a certain zone has been swapped with a wire from another zone. This fault cannot be detected by the ground fault detection and/or impedance measurement, as the impedance reference values may already have been set incorrectly.

10. Line Supervision Comparison Table

This table is intended to help you to decide which type of line monitoring fits best for your project.

Feature/keyword	IMP	EOL	PEOL
Wiring	Nothing additional is needed.	The EOL modules need to be connected to a loudspeaker line and ground.	The PEOL modules need to be connected to a loudspeaker line and a GPI.
Fault contact needed	No	No	Yes
Detect a line interruption to a single loudspeaker	Possible, if not more than five loudspeakers (all with the same impedance) are connected to one line.	Possible, if an EOL module is installed on each branch end.	Possible, if a PEOL module is installed on each branch end.
Detect a missing loudspeaker	Possible, if not more than five loudspeakers (all with the same impedance) are connected to one line.	Not possible	Not possible
Detect a short circuit	Possible	Possible	Possible
Detect an open circuit	Possible, if not more than five loudspeakers (all with the same impedance) are connected to one line.	Possible	Possible
In-Line volume control	Possible, but each volume control needs a priority relay to bypass the volume control.	Possible, but each volume control needs to be placed after the EOL board, inside the loudspeaker cabinet. A priority relay to bypass the volume control is also needed.	Possible, but each volume control needs to be placed after the PEOL board, inside the loudspeaker cabinet. A priority relay to bypass the volume control is also needed.
In-Line volume control in EN54-16 certified systems	In-Line volume control is not allowed to be used in EN54-16 certified systems, independent of the line supervision method.		
EN54 certification	Yes, if permanent IMP is used.	Yes (recommended)	
Impedance reference	Impedance reference values need to be set for all three supervision types.		
Audio interruption	Yes	No	No
Ground fault detection	Ground fault detection is obligatory and cannot be disabled, no matter which line supervision type is used.		